

Hitachi Power Tools

SERVICE MANUAL

CONFIDENTIAL
NR 1890DC: K858
NR 1890DBCL:
NR 1890DR: K859
NR 1890DBRL:
Jul. 2017

PRODUCT NAME

Hitachi 18 V Cordless Strip Nailer

Models NR 1890DC NR 1890DBCL
NR 1890DR NR 1890DBRL

CONTENTS

Page

TROUBLESHOOTING GUIDE1

1. Troubleshooting and corrective action1
2. Corrective action when the orange LED blinks6
3. Maintenance mode7
4. Resetting error mode (when the orange LED is blinking)7

REPAIR GUIDE8

1. Precautions on disassembly and reassembly8
 - Preparation before disassembly8
 - Disassembly and reassembly of the magazine section9
 - Disassembly and reassembly of the output section12
 - Replacement of the piston ass'y23
 - Replacement of sensor (B)26
 - Feeding compressed air27
 - Checking after reassembly29
 - Tightening torque30
 - Connecting diagram31

STANDARD REPAIR TIME (UNIT) SCHEDULES32

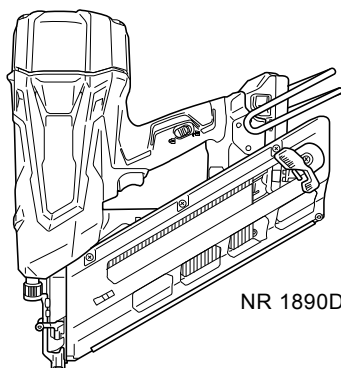

NR 1890DC

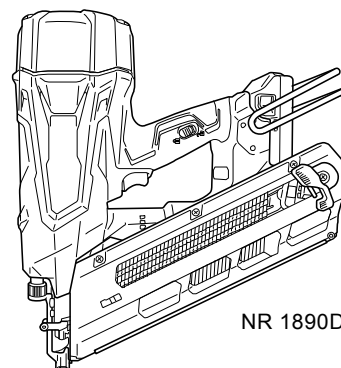

NR 1890DR

HITACHI

Hitachi Koki Co., Ltd.
Overseas Sales Division

N

TROUBLESHOOTING GUIDE

1. Troubleshooting and corrective action

Problem	Possible cause (*: Most common cause)	Inspection method	Corrective action
1. Nails cannot be driven.	<Nails> <ul style="list-style-type: none"> Magazine is not loaded with specified Hitachi genuine nails. Magazine is loaded with abnormal nails (e.g., bent nails, abnormal collation) 	<ul style="list-style-type: none"> Check whether the magazine is correctly loaded with specified nails. 	<ul style="list-style-type: none"> Use specified nails. Remove abnormal nails and load the nailer with proper nails.
	<ul style="list-style-type: none"> Worn-out piston tip 	<ul style="list-style-type: none"> Check whether the piston tip is excessively worn. 	<ul style="list-style-type: none"> Replace defective parts. See page 23.
	<ul style="list-style-type: none"> Piston trouble 	<ul style="list-style-type: none"> Check the piston for any trouble (e.g., deformation, burring, break). 	<ul style="list-style-type: none"> Replace defective parts. See page 23.
	<Magazine section> <ul style="list-style-type: none"> Nail feeder trouble (deformation, burring, break) Worn-out nail rail or magazine plate 	<ul style="list-style-type: none"> Check the nail feed section for any trouble (e.g., burring, deformation, break, excessive wear). 	<ul style="list-style-type: none"> Remove burring. Correct the deformed portion. Replace defective parts.
	<ul style="list-style-type: none"> Nail guide groove of blade guide (B) too narrow or wide Nail guide groove trouble (protrusion or burring) of blade guide (B) Step in the nail shank guide groove between blade guide (B) and magazine Nail guide groove of the magazine too narrow or wide Nail guide groove trouble (deformation or burring) of the magazine 	<ul style="list-style-type: none"> Load nails in the nailer and make sure the nailer works normally. 	
	* Unwanted objects (e.g., dust, wood dust, adhesives) in the nail guide groove of blade guide (B), magazine and nail feeder	<ul style="list-style-type: none"> Load nails in the nailer and make sure the nailer works normally. 	<ul style="list-style-type: none"> Remove unwanted objects (e.g., dust, wood dust, adhesives).
	<ul style="list-style-type: none"> Loose bolts of the output section and the magazine section 	—	<ul style="list-style-type: none"> Tighten the bolts at the specified torque.
	<ul style="list-style-type: none"> Nail feeding trouble 	<ul style="list-style-type: none"> Check the nail feeder slide surface for dust. Check the nail feeder slide surface for deformation. Check the ribbon spring for damage. 	<ul style="list-style-type: none"> Replace defective parts.
	<ul style="list-style-type: none"> No compressed air in the nailer Compressed air leak 	<ul style="list-style-type: none"> Fill up the nailer with compressed air, leave the nailer still for one day, and then check the nailing work. Check the sealing surfaces, X-rings, and O-rings inside the cylinder, piston, chamber cover, and chamber base for flaws, unwanted objects, and other failures. 	<ul style="list-style-type: none"> Supply compressed air. Disassemble the nailer and clean the chamber, piston, and their vicinity. Replace the sealing parts.

Problem	Possible cause (*: Most common cause)	Inspection method	Corrective action
2. Nails are driven but bent.	*• Worn-out piston tip *• Broken or worn-out blade rack	• Check the piston tip for excessive wear. • Check the blade rack for break or wear.	• Replace defective parts. See page 23.
	• Nails are not completely fed into the injection port. • Unspecified nails are used.	• Check whether the magazine is correctly loaded with specified nails.	• Use specified nails. • Remove abnormal nails and load the nailer with proper nails.
	• Wood material too hard to be nailed	• Drive nails into soft wood and check whether the driven nails are bent.	• This nailer is not for hard wood.
	• Deformed output section	• Check the tips of the pushing lever and blade guide for warp, deformation and excessive wear.	• Replace defective parts.
3. Nails cannot be driven into the workpiece completely: the heads cannot be made flush.	• Worn-out piston tip	• Check the piston tip for excessive wear.	• Replace defective parts. See page 23.
	*• Worn-out piston rack	• Check the piston rack for excessive wear.	• Replace defective parts. See page 23.
	• Inadequate adjuster control	• Set the adjuster to nail deeper and then nail again.	• Set the adjuster properly.
	• Wood material too hard to be nailed	• Drive nails into soft wood and check whether the nail heads are lifted.	• This nailer is not for hard wood.
	• Weak thrusting force against wood to be nailed	• Firmly thrust the nailer against wood to be nailed and start nailing. Check whether the nail heads are still lifted.	• Follow the nailer operation guide.
	• Deformed output section	• Check the nail guide groove of the pushing lever and blade guide for any trouble (e.g., deformation, excessive wear, burrs).	• Replace defective parts.
	• Insufficient grease on the cylinder and piston section	• Check the greasing condition of the cylinder and piston section.	• Replenish grease.
4. Nails jam.	*• Abnormal nails are used (e.g., bent nails, abnormal collation) • Nails are not completely fed into the injection port.	• Check whether the magazine is correctly loaded with specified nails.	• Use specified nails. • Remove abnormal nails and load the nailer with proper nails.
	• Worn-out piston tip	• Check whether the piston tip is excessively worn.	• Replace defective parts. See page 23.
	• Wood material too hard to be nailed	• Drive nails into soft wood and check whether nails jam.	• This nailer is not for hard wood.

Problem	Possible cause (*: Most common cause)	Inspection method	Corrective action
4. Nails jam.	• Piston slide surface trouble (e.g., galling, break)	• Check the surfaces on which the piston slides (blade guides (A) and (B) and pushing levers (A) and (B)).	• Replace defective parts.
	<Magazine section> • Nail feeder trouble (e.g., deformation, burring, break)	• Check the nail feed section for any trouble (e.g., burring, deformation, break, excessive wear).	• Remove burring. • Correct the deformed portion. • Replace defective parts.
	• Nail guide groove of the blade guide (B) too narrow or wide • Nail guide groove trouble (e.g., protrusion, burrs, excessive wear) of blade guide (B) • Nail guide groove of the magazine too narrow or wide • Nail guide section trouble (e.g., deformation, burrs) of the magazine	• Load nails in the nailer and check that the nailer works normally.	• Remove burring. • Replace defective parts.
	• Unwanted objects (e.g., dust, wood dust, adhesives) in the nail guide groove of the magazine and nail feeder	• Load nails in the nailer and check that the nailer works normally.	• Remove unwanted objects (e.g., dust, wood dust, adhesives).
	• Deformed output section	• Check pushing lever (A) and blade guides (A) and (B) for deformation, excessive wear, and burrs.	• Replace defective parts.
	• Misaligned assembly of blade guide (B) and magazine	• Set Hitachi genuine nails in the nailer and lightly push them against the magazine. Make sure the nail tips closely touch the nail guide surface of blade guide (B). (See "Disassembly and reassembly of the magazine section.")	• Reassemble blade guide (B). See page 11.
	• Loose bolts of the output section and magazine section	—	• Tighten the bolts at the specified torque.
5. Nailing started by single triggering.	*• Malfunction caused by unwanted objects (e.g., adhesive, dust) near pushing lever (A), (B) or blade guide (A) or by deformation of the lever or blade guide	• Check that pushing lever (A) moves smoothly (in a body).	• Clean the pushing lever and the blade guide. Then apply oil to them. • Replace defective parts.
	• Broken or worn-out pushing lever spring (B)	• Check the spring for any trouble.	• Replace defective parts.

Problem	Possible cause (*: Most common cause)	Inspection method	Corrective action
6. No nailing operation without motor rotation sound.	<ul style="list-style-type: none"> • Dry-fire lockout mechanism is activated. 	<ul style="list-style-type: none"> • Count the number of remaining nails. There should be 9 or more remaining nails. 	<ul style="list-style-type: none"> • Load nails.
	<ul style="list-style-type: none"> *• Wire-related trouble of wiring, switch cable (A), and sensor (B) 	<ul style="list-style-type: none"> • Check whether the wires and sensor (B) are firmly soldered. • Check whether the rotor emits a parching smell. • Check the conductivity of the switch and microswitch by using a multimeter. <p>[Checking procedure]</p> <p>(1) When switch cable (A) is not defective:</p> <ul style="list-style-type: none"> • Set the switch to OFF and apply tester probes to the points shown in the figure below. Make sure the terminals are not electrically connected. • Set the switch to ON and apply tester probes to the points shown in the figure below. Make sure the terminals are electrically connected. <p>(2) When the microswitch is not defective:</p> <ul style="list-style-type: none"> • Set the switch to ON and apply tester probes to the points shown in the figure below. Make sure the contacts are electrically connected. • Set the switch to OFF and apply tester probes to the points shown in the figure below. Make sure the contacts are not electrically connected. 	<ul style="list-style-type: none"> • Firmly resolder the disconnected wires. • Replace defective parts.

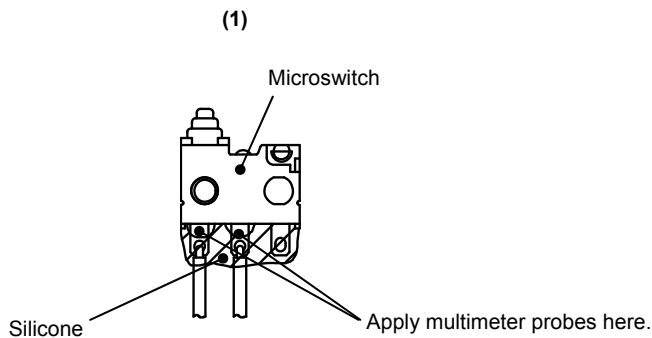

NOTE: Remove the silicone a little and apply the multimeter probes to the exposed terminal metal.

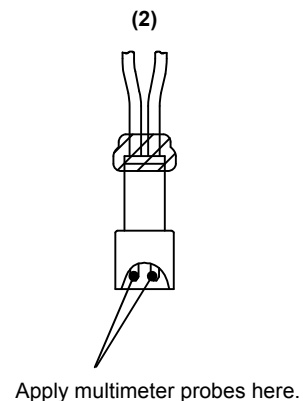

Problem	Possible cause (*: Most common cause)	Inspection method	Corrective action
7. No nailing operation with the orange LED blinking. *See page 6.	*• Broken movable part that disabled nailing work.	• Check the movable part for any trouble (e.g., deformation, break, excessive wear).	• Replace defective parts.
	• Disconnected wiring and stator	• Check the wires and sensor assemblies for breaks or disconnection. • Check the conductivity of the stator.	• Replace defective parts.
	*• Power transmission failure due to broken gears	• Check that the gear turns smoothly. See page 18. • Check the gear box ass'y for breaks.	• Replace defective parts.
	• Sensor (C) trouble	• Visually check the sensor wires for breaks.	• Replace defective parts.
	• Excessively charged compressed air	• Check the LED lighting pattern.	• Move the piston down to the bottom dead point. Discharge the compressed air. Use the reduction valve set to feed compressed air again. See pages 27 to 28.
8. No nailing operation with the red 2 LEDs blinking	*• Overheat protector is activated.	• Cool the nailer body and check the nailing work.	—
	*• Overcool protector is activated	• Warm the nailer body and check the nailing work.	—
9. No nailing operation with the red LED blinking	*• Low battery voltage	• Use a fully charged battery and check the nailing work again.	• Charge or replace the battery.

For others

Select the nailing operation mode.
(Full sequential actuation/Contact actuation)



Red LED





For New Zealand

Select the nailing operation mode.
(Contact actuation only)

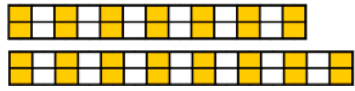

Red LED

2. Corrective action when the orange LED blinks

No.	Orange LED lighting pattern	Possible cause	Corrective action
1	 Power switch is automatically turned off after about 10 seconds.	<ul style="list-style-type: none"> Reversed magnet polarity of position detector Sensor (C) failure or disconnection Failure of one-way clutch in gear box 	<ul style="list-style-type: none"> Replace defective parts.
2	 Power switch is automatically turned off after blinking 5 times (about 5 seconds).	<ul style="list-style-type: none"> Idle by broken gear 	<ul style="list-style-type: none"> Replace defective parts.
3	 Power switch is automatically turned off after blinking 6 times (about 6 seconds).	<ul style="list-style-type: none"> Broken wiring 	<ul style="list-style-type: none"> Replace defective parts.
4	 Power switch is automatically turned off after blinking 7 to 8 times (about 7 to 8 seconds).	<ul style="list-style-type: none"> Lock by broken gear Lock by worn-out piston rack Lock by broken piston bumper Broken wiring 	<ul style="list-style-type: none"> Replace defective parts.
5	 Power switch is automatically turned off after about 9 seconds.	<ul style="list-style-type: none"> Excessively charged compressed air Deformed or broken moving parts Moving parts are out of grease. 	<ul style="list-style-type: none"> Replace defective parts. Move the piston down to the bottom dead point. Discharge the compressed air. Use the reduction valve set to feed compressed air again. Replace moving parts. Lubricate the moving parts with grease.
6	 Power switch is automatically turned off after blinking 10 times (about 10 seconds).	<ul style="list-style-type: none"> Broken wiring 	<ul style="list-style-type: none"> Replace defective parts.

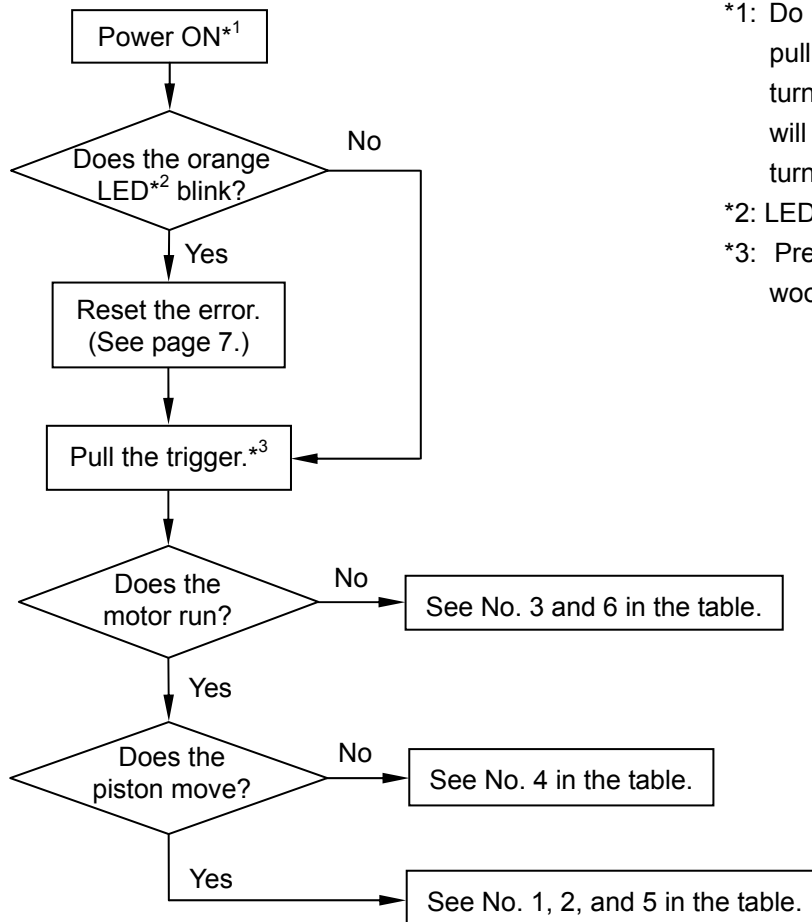

*1: Do not press the pushing lever and/or pull the trigger during the process of turning the power switch ON. Doing so will prevent the power switch from turning ON.

*2: LED of battery indicator

*3: Press the pushing lever against the wood before pulling the trigger.

3. Maintenance mode

Maintenance mode is used to move the piston down to the bottom dead point in preparation for feeding compressed air or overhauling the nailer. To set MAINTENANCE mode, hold down both the nailing operation switch* and the power switch on the operation panel for at least five seconds.

*: The nailing operation switch is not provided for the products intended for New Zealand. Peel back the operation panel and press the inside button (red).

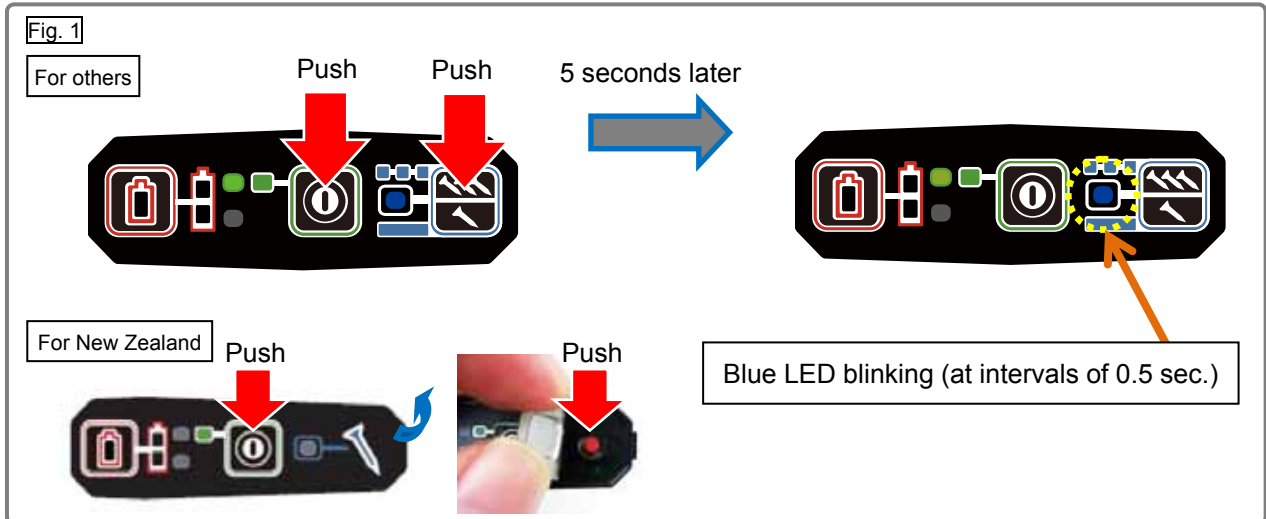

Indication: Indicated by the blue LED on the operation panel blinking (at intervals of 0.5 second).

Be careful not to mistake the blinking for contact actuation mode (at intervals of 1.0 second).

Function: Starts the motor when the pushing lever is pressed against wood and the trigger is pulled.

Stops the motor when detecting two motor rotations.

4. Resetting error mode (when the orange LED is blinking)

Error indication: Indicated by the orange battery level indicators blinking (at intervals of 0.5 second).

The power indicator turns off automatically 10 seconds later.

To reset the mode: Hold down both the battery indicator switch and the nailing operation switch for at least five seconds.

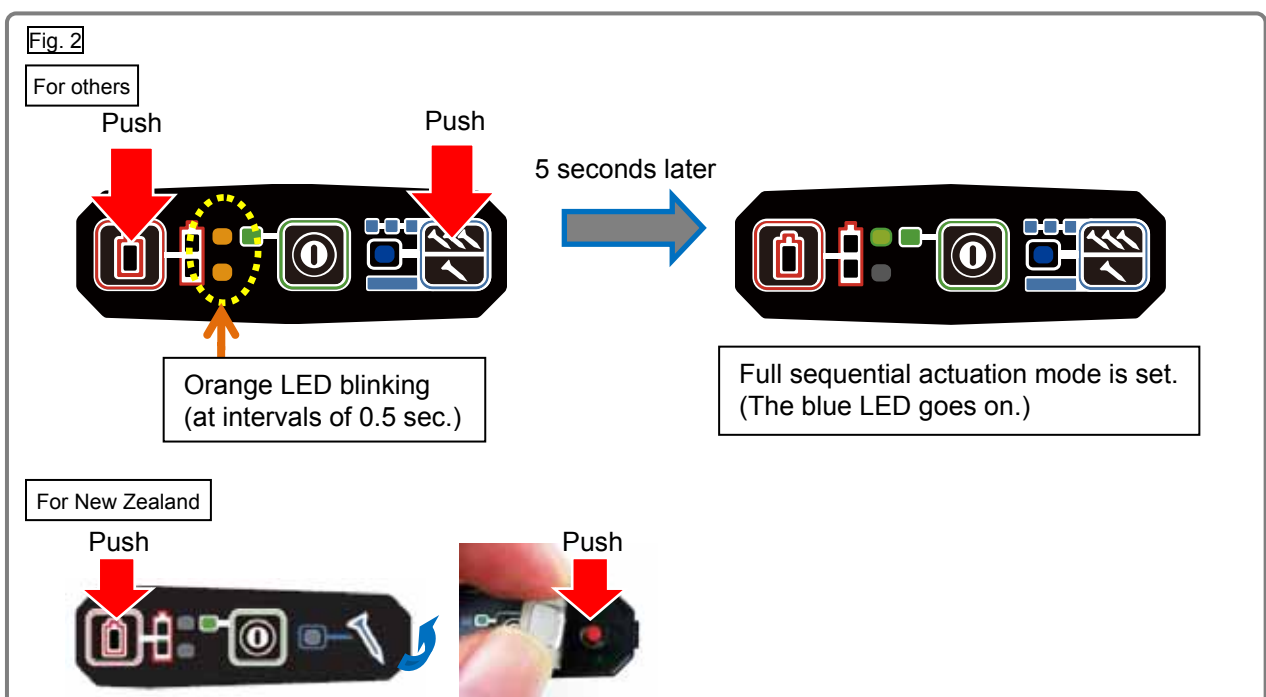

REPAIR GUIDE

The following describes the most essential precautions on disassembly and reassembly of the nailers. The cordless strip nailer Models NR 1890DC, NR 1890DBCL, NR 1890DR, and NR 1890DBRL mainly consist of two sections: the output section and the magazine section.

1. Precautions on disassembly and reassembly

[Bold] numbers in the description below correspond to the item numbers in the parts list and exploded assembly diagram for the Models NR 1890DC and NR 1890DBCL, and **(Bold)** numbers to those for the Models NR 1890DR and NR 1890DBRL.

WARNING: Always remove the battery from the main body before starting repair or maintenance work. Because the tool is cordless, inadvertently activating the switch with the battery left in the main body will start the motor rotating unexpectedly, and could cause serious injury.

Preparation before disassembly

1. Removal of the hook

Remove the Hook **57** by removing the Low Head Hex. Socket Bolts M4 x 8 **58** for easy disassembly work, although disassembly can be done without removing the Hook **57**.

2. Removal of housing (C)

- When the nailer is enabled to nail, set MAINTENANCE mode and move the Piston Ass'y **15** down to the bottom dead point referring to "Feeding compressed air" on page 27.
- Remove the Tapping Screw D4 x 20 **44** and remove Housing (C) **45**.
- Remove the Charge Cap **8** by using a hexagonal socket wrench.
- Push the valve core to release compressed air as shown below.

Fig. 3



Disassembly and reassembly of the magazine section

1. Disassembly

(1) Models NR 1890DC and NR 1890DBCL

- Remove the Nylock Bolt M5 [85] that fastens the magazine ass'y to the Housing Set [46] and two Nylock Bolts M5 x 22 [34] that fasten the magazine ass'y to the Nose [17].
- Remove the three Tapping Screws D4 x 16 [91], Cap Nut M3 [81], and Step Bolt M3 [89].
- Remove the Magazine Guard [90] from the magazine ass'y and remove Magazine Cover (B) [84] from Magazine Cover (A) [88]. Then remove Blade Guide (B) [76].
- Remove the Tapping Screw D5 x 20 [93] that fastens Magazine Cover (A) [88] to Nail Feeder (B) [79]. Then remove the Feeder Knob [92] and Ribbon Spring [80].
- Remove Pushing Lever Stopper (A) [72], Pushing Lever Stopper (B) [74], and two Springs [73] from Magazine Cover (A) [88].
- Remove the Nail Rail [87] from Magazine Cover (B) [84] and remove the Magazine Plate [87].

Fig. 4 • Models NR 1890DC and NR 1890DBCL

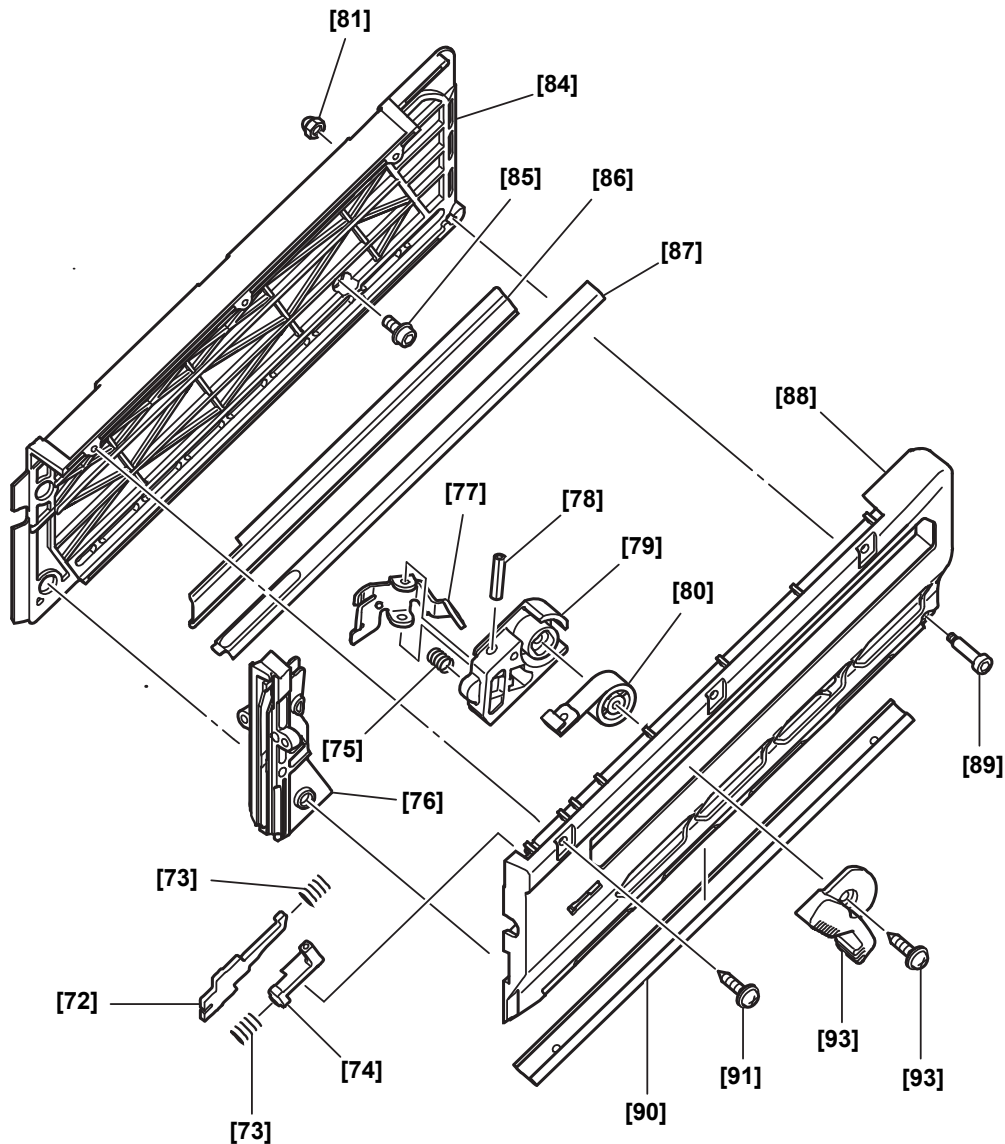

(2) Models NR 1890DR and NR 1890DBRL

- Remove the Nylock Bolt M5 x 18 (86) that fastens the magazine ass'y to the Housing Set (46) and two Nylock Bolts M5 x 22 (34) that fastens the magazine ass'y to the Nose (17).
- Remove the three Tapping Screws D4 x 16 (91), Cap Nut M3 (81), and Step Bolt M3 (89).
- Remove the Magazine Guard (90) from the magazine ass'y and remove Magazine Cover (B) (84) from Magazine Cover (A) (88). Then remove Blade Guide (B) (76).
- Remove the Tapping Screw D5 x 20 (93) that fastens Magazine Cover (A) (88) to Nail Feeder (B) (79). Then remove the Feeder Knob (92) and Ribbon Spring (80).
- Remove Pushing Lever Stopper (A) (72), Pushing Lever Stopper (B) (74), and two Springs (73) from Magazine Cover (A) (88).
- Remove Nail Rail (C) (87) from Magazine Cover (B) (84) and remove the Magazine Plate (85).

Fig. 5 • Models NR 1890DC and NR 1890DBRL

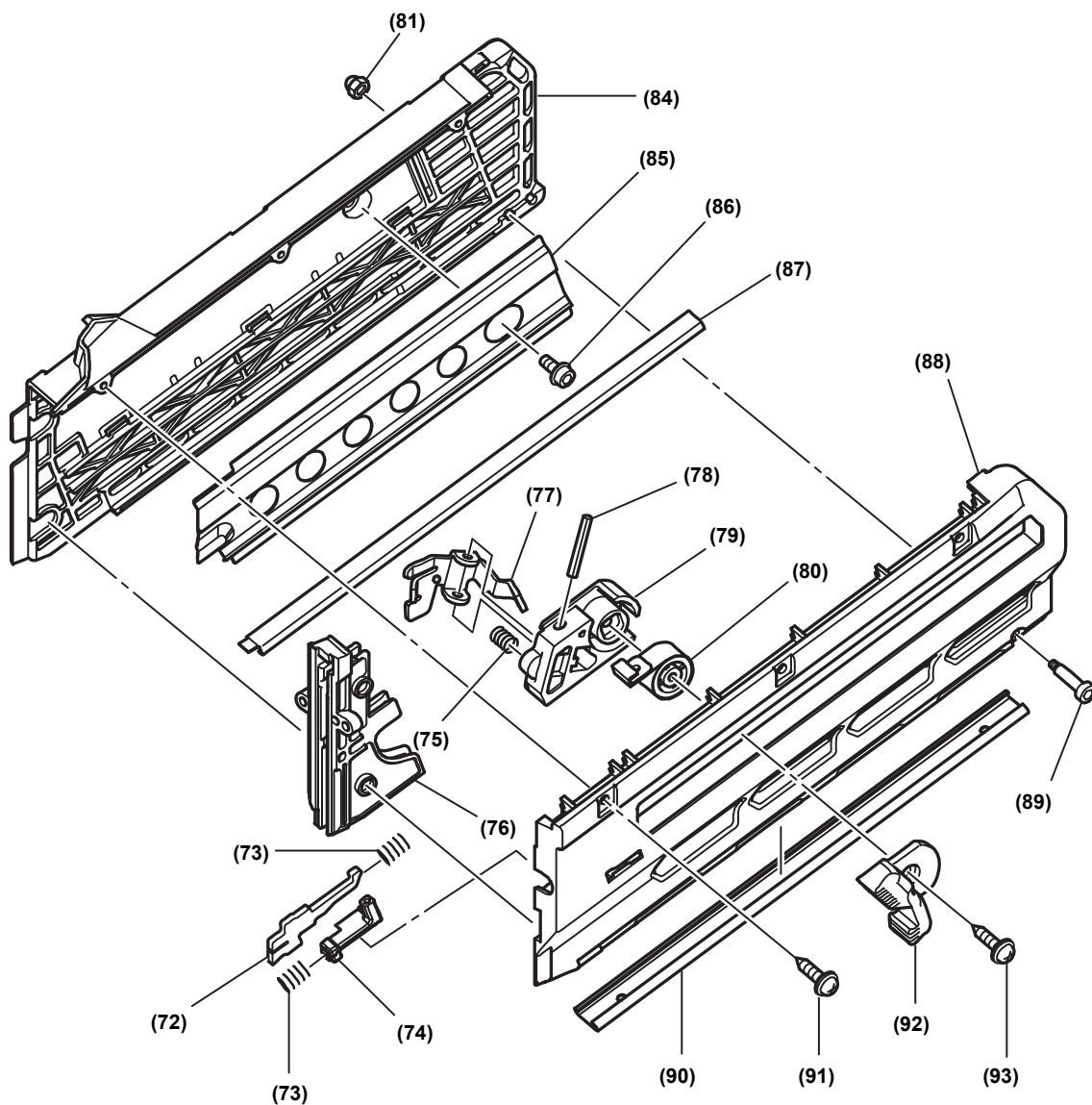

2. Reassembly

(1) Models NR 1890DC and NR 1890DBCL

Reverse the disassembly procedure to reassemble. Note the following points:

- Insert the protrusion of the Nail Rail **[87]** into the nail head inlet of Blade Guide (B) **[76]**.

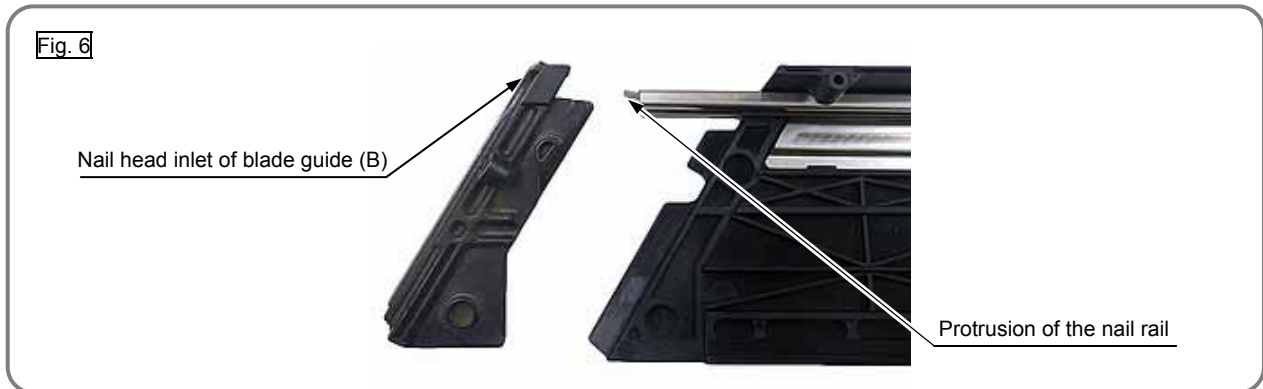

(2) Models NR 1890DR and NR 1890DBRL

Reverse the disassembly procedure to reassemble. Note the following points:

- Position the concave portion of Blade Guide (B) **(76)** on Magazine Cover (B) **(84)** side between the Magazine Plate **(85)** and Magazine Cover (B) **(84)** as shown below.

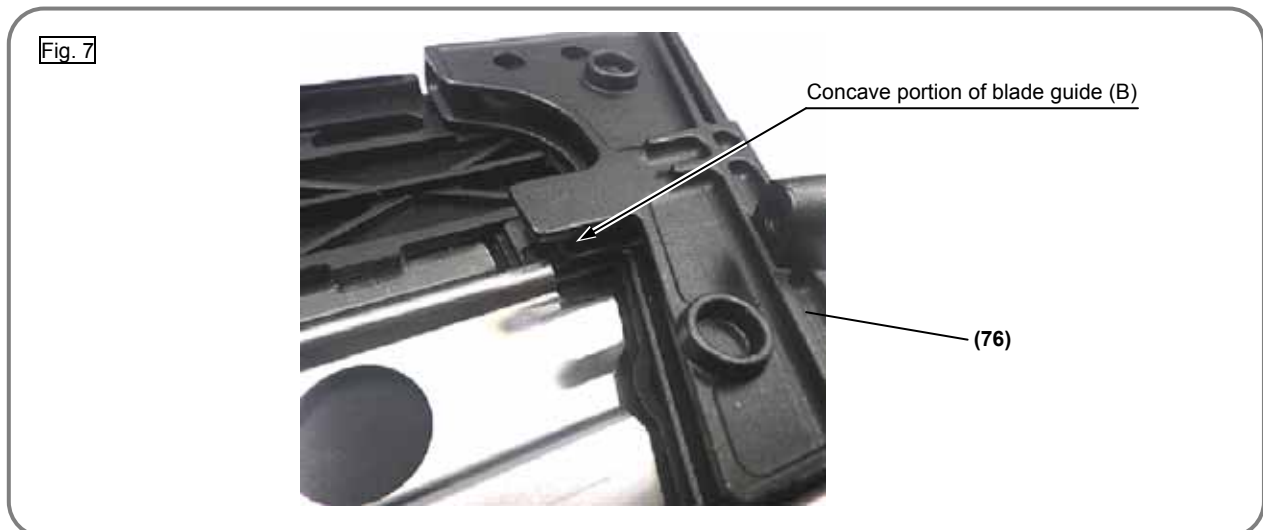

- Insert the protrusion of Nail Rail (C) **(87)** into the nail head inlet of Blade Guide (B) **(76)**.

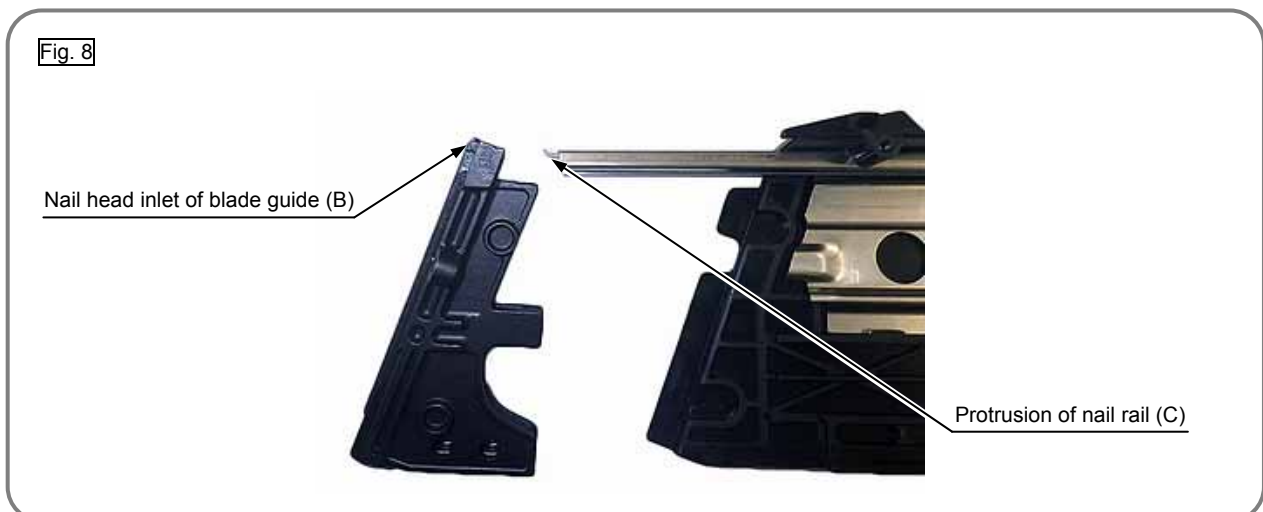

Disassembly and reassembly of the output section

1. Removal of the power assembly and wiring

- The nailer has two Housing Set 46 halves: housing (A) with a HITACHI logo mark on one side and housing (B) on the other side.
- For safety, push the valve core once more and check that compressed air is completely released.
- Remove the Hex. Socket Bolt M6 1 and detach the Top Cover 2.
- Remove the fourteen Tapping Screws D4 x 20 44 that fasten housing (A) and housing (B).
- Holding the battery portion of housing (B), gently open and remove the Housing Set 46.
- Remove the Trigger 54 and Spring (T) 53 from housing (A).
- Remove Rubber Cushion (A) 18 from housing (A).
- Disconnect the connectors of Sensor (B) 63, Sensor (C) 60, Switch Cable (A) 52, and Wiring 51.
- Remove the two O-rings (I.D 2.5) 50 from Switch Cable (A) 52. Be careful not to lose the O-rings.
- Carefully lift the Chamber Base 10 and Nose 17 to remove the power assembly from housing (A) and Rotor 83.
- Remove the Gear Box 82 and Bumper (B) 59 from the power assembly.
- Firmly hold the stator of the Wiring 51 (as the Rotor 83 has strong magnetic force), slowly push the ball bearing (opposite to the pinion) of the Rotor 83 in direction "A" to separate the Wiring 51 from the Rotor 83 as shown in the figure below.

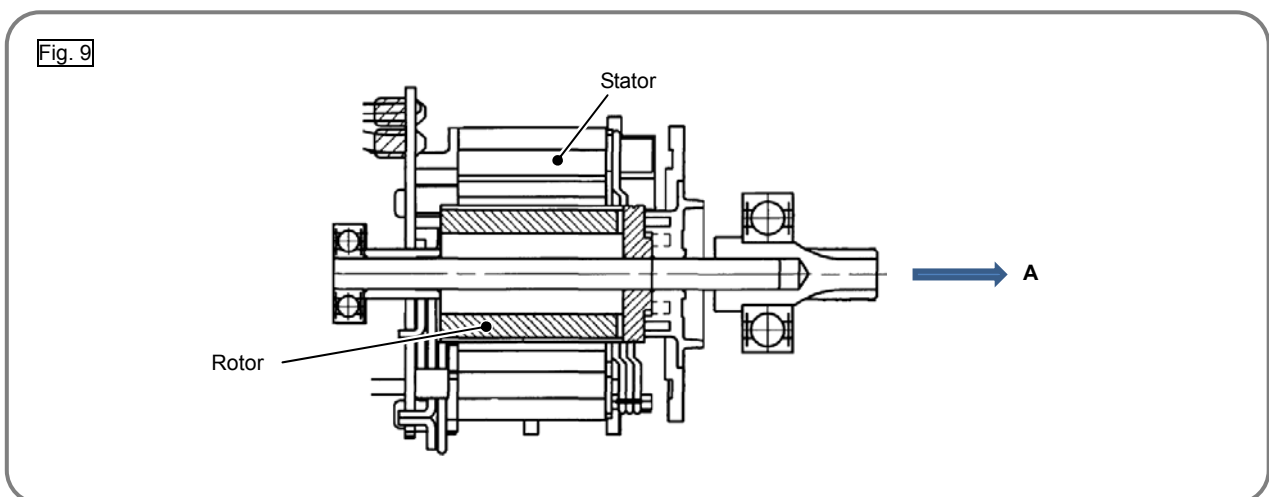

- Remove the Wiring 51 from housing (A).
- Remove Lever (C) 55 from Lever (A) 56.
- Remove Lever (A) 56 from housing (A).

2. Disassembly of the power assembly

NOTE: • See pages 23 to 25 for replacement of only the Piston Ass'y 15.

- Make alignment marks on the Chamber Base 10 and Cylinder 5 as shown in the figure below so as to indicate the coupling positions before disassembling the power assembly.

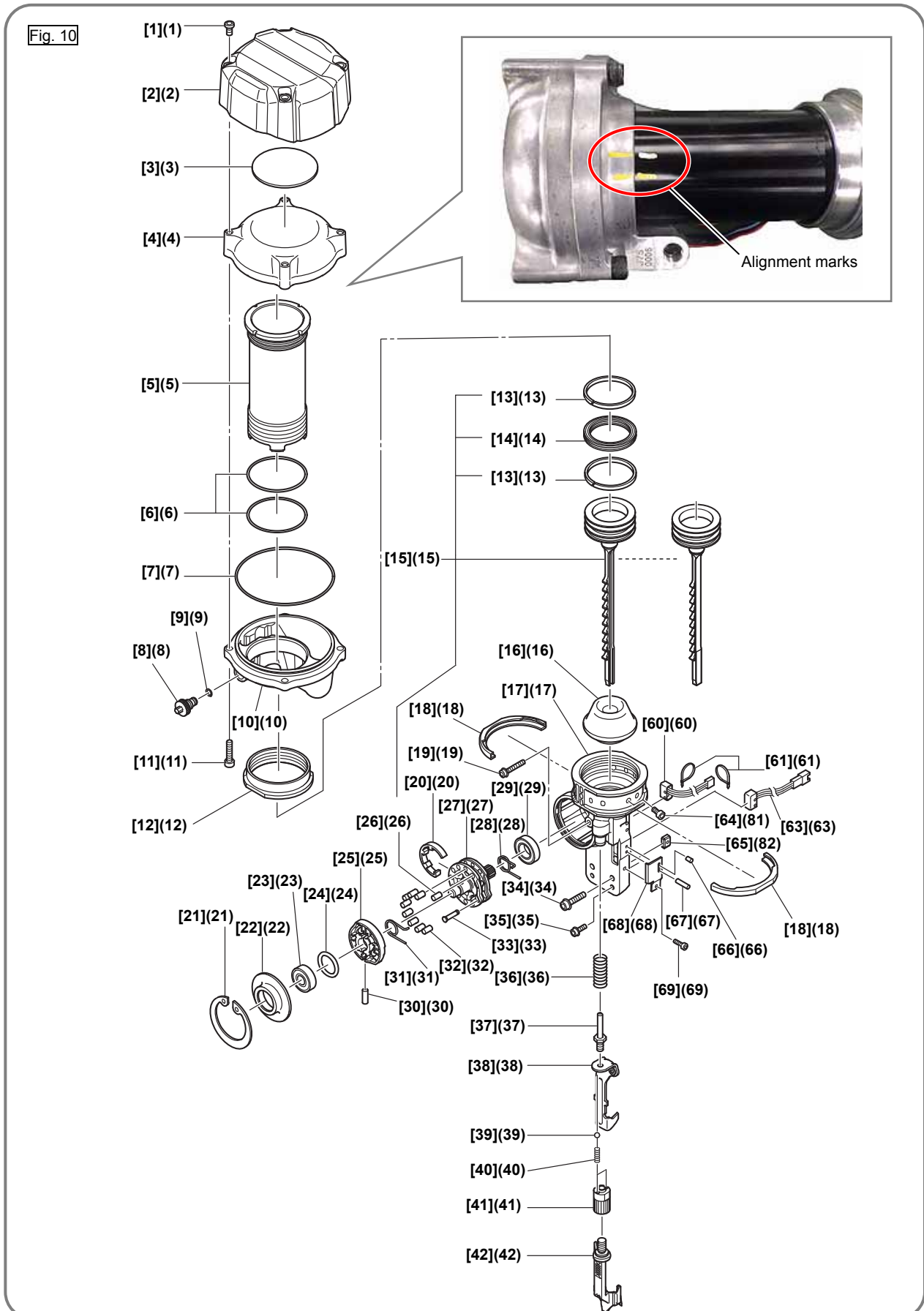

- Remove the valve core from the Chamber Base 10 by using a commercial valve core tool. (See Fig. 11.)



- Remove the four Nylock Bolts M6 11 that fasten the Chamber Base 10 and Chamber Cover 4, and remove the Chamber Base 10.

NOTE: If it is difficult to remove the Chamber Base 10, temporarily tighten at least two Nylock Bolts M6 11 so that the threaded portion is shown 3.5 mm to 6.5 mm as shown in Fig. 12. Mount the reduction valve set and feed compressed air to remove the Chamber Base 10.

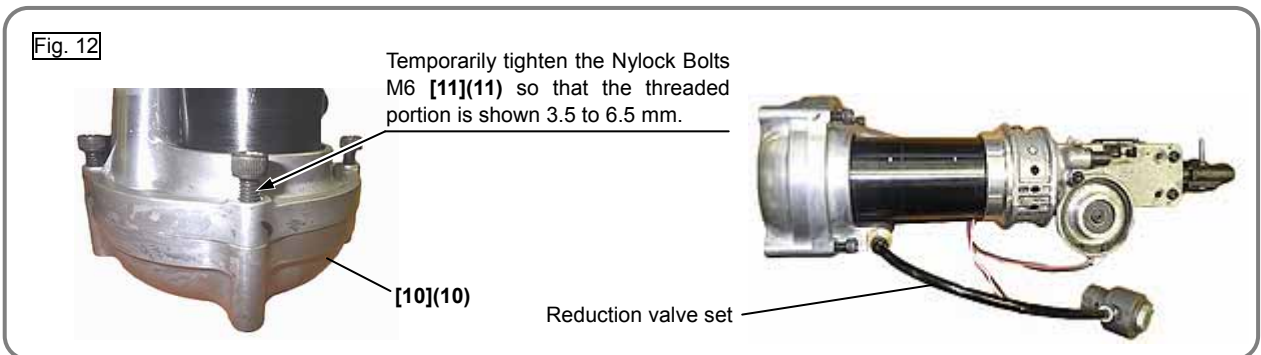

- Remove the O-ring (I.D 94.5) 7 from the Chamber Base 10.
- Push in the Piston Ass'y 15 from Blade Guide (A) 70 side to the Cylinder 5 side to remove it.
- Remove the Hex. Socket Hd. Bolt M5 64 from the Nose 17.

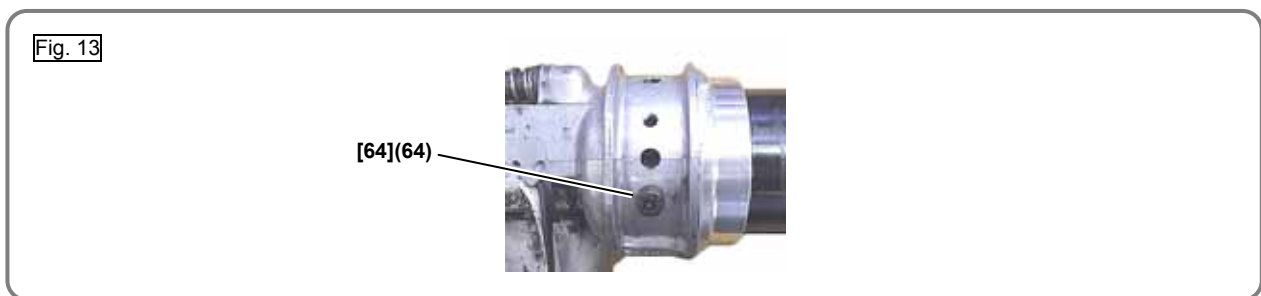

- Move the Chamber Base 10 from the Cylinder 5 contact surface to the Nose 17 side and secure the Cylinder 5 and Chamber Base 10 with tape as shown below.

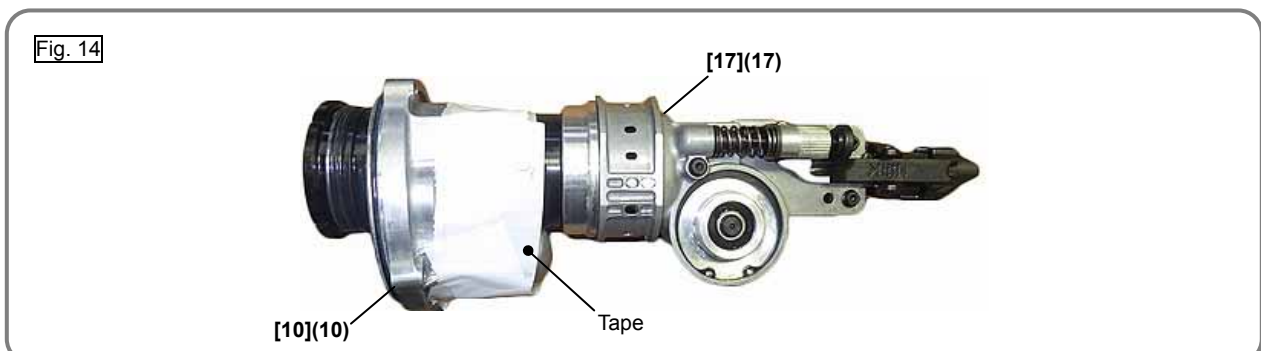

- Fix the hexagonal portion of the J-400 special socket. Fit the claws of the J-400 special socket in the notches on the end surface of the Cylinder 5. Loosen the Special Nut M58 12 and turn the Nose 17 to remove it from the Cylinder 5.

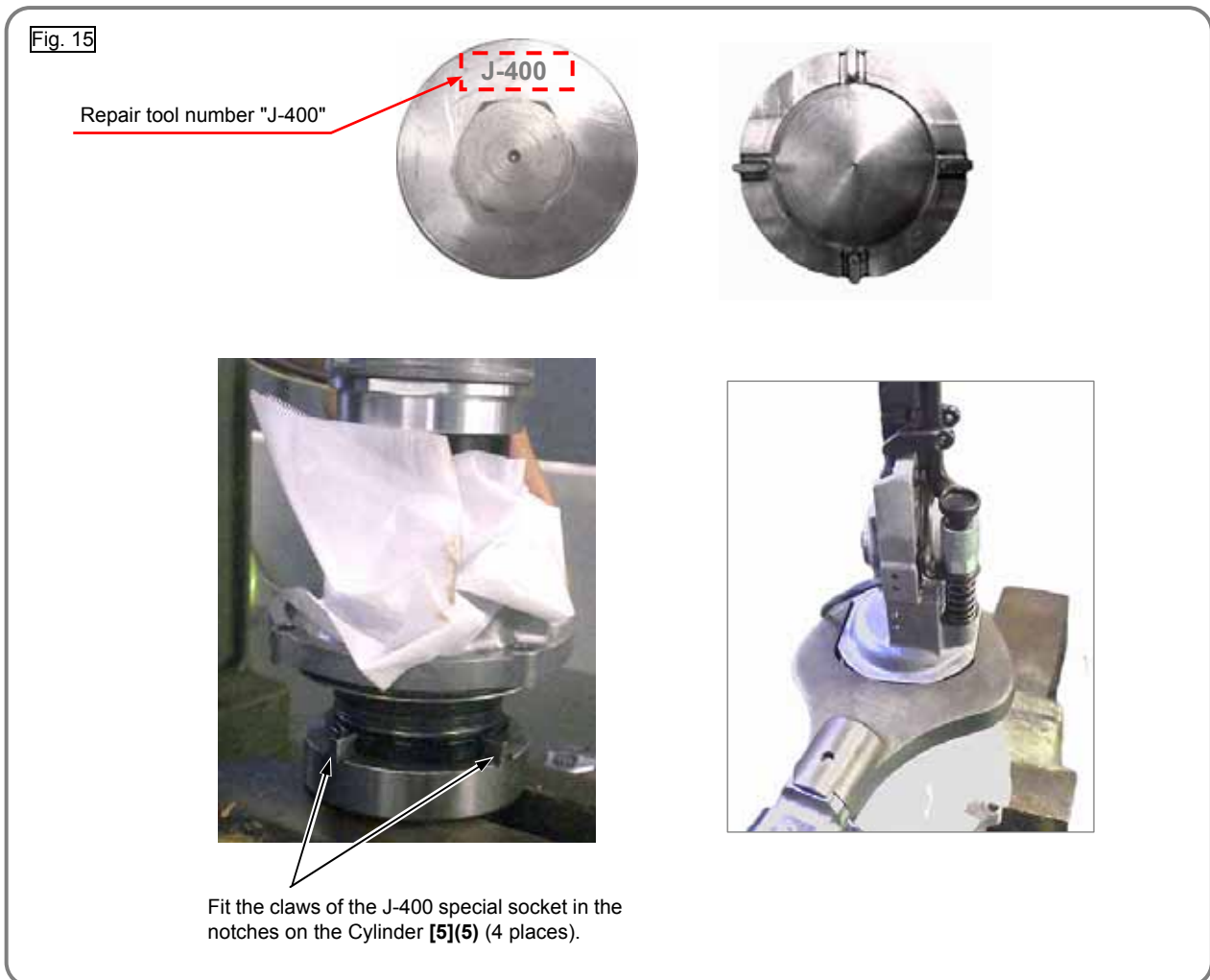

- Turn the Special Nut M58 12 and remove it from the Cylinder 5.
 - Remove the Chamber Base 10 from the Cylinder 5 being careful not to damage the sealing surfaces.
 - Remove the two O-rings (I.D 55.5) 6 from the Cylinder 5.
 - Remove the Slide Ring 13 and X-ring 14 from the Piston Ass'y 15.
 - Remove the Piston Bumper 16 from the Nose 17.
 - Remove the Retaining Ring D52 21 from the Nose 17 and pull out the Bearing Holder 22 and Pin Wheel 27.
- NOTE: The Pin Wheel 27 can be removed only after removing the Piston Ass'y 15.**
- Remove the Ball Bearing 6000VV 23 and Ball Bearing 6902VV 29 from the Pin Wheel 27.
 - Remove the Needle Roller D3 30 from the Pin Wheel 27 and then remove the Position Detector 25.
 - Remove the eight Needle Rollers D4 32 and one Needle Roller D4.5 26 from the Pin Wheel 27. Remove Wheel Spring (A) 31, Wheel Spring (B) 28, and Pin (A) 33.
 - Remove Felt (P) 20 from the Pin Wheel 27.
 - Remove the Roll Pin D3 x 20 71 from Blade Guide (A) 70. Turn the Adjuster 41 and remove Pushing Lever (A) 42, Pushing Lever (B) 38, and Pushing Lever Spring (B) 36.

- Remove the Special Bolt M6 37, Adjuster 41, Adjuster Spring 40, and Steel Ball D3.175 39 from Pushing Lever (B) 38.
- Remove the two Nylock Bolts M4 x 14 35 and one Nylock Bolt M4 x 25 19 from the Nose 17, then remove Blade Guide (A) 71.
- Remove the Nylock Hex. Socket Hd. Bolt M3 69 and Guide Plate Holder 65 from the Nose 17, then remove Guide Plate (P) 68.
- Cut the two Wire Bands 61 that fixes Sensor (B) 63 and Sensor (C) 60, then remove Sensor (C) 60.
- Remove the Roll Pin D2.5 66 and Roll Pin D2.5 x 16 67 that fix Sensor (B) 63 referring to page 26.

NOTE: Sensor (C) 60 can be removed only after removing Blade Guide (A) 71.

3. Reassembly of the power assembly

Reverse the disassembly procedure to reassemble. Note the following points:

- Use the specified tightening torques. (See page 30.)
- Protect the sealing parts (e.g., O-rings, X-rings, valve core, etc.) against contaminants and scratches during reassembly.
- Always use brand-new seal lock bolts. Never reuse the old bolts.
- Use the alignment marks (made before disassembly) for precise positioning when mounting the Chamber Base 10 on the Cylinder 5.
- Slowly tighten the four Nylock Bolts M6 11 to fasten the Chamber Base 10 and Chamber Cover 4. Be careful not to pinch and damage the O-ring (I.D 94.5) 7.
- Impregnate Felt (P) 20 with about 1 g of Molub-Alloy 777-1 grease by hand before reassembly.
- Mount the Pin Wheel 27 to the Position Detector 25 so that the end surface side of Pin (A) 33 is aligned with the notch of the Position Detector 25 as shown in Fig. 16.

NOTE: If the Position Detector 25 is not precisely located, an error (causing the orange LED of the battery indicator to blink) may occur.

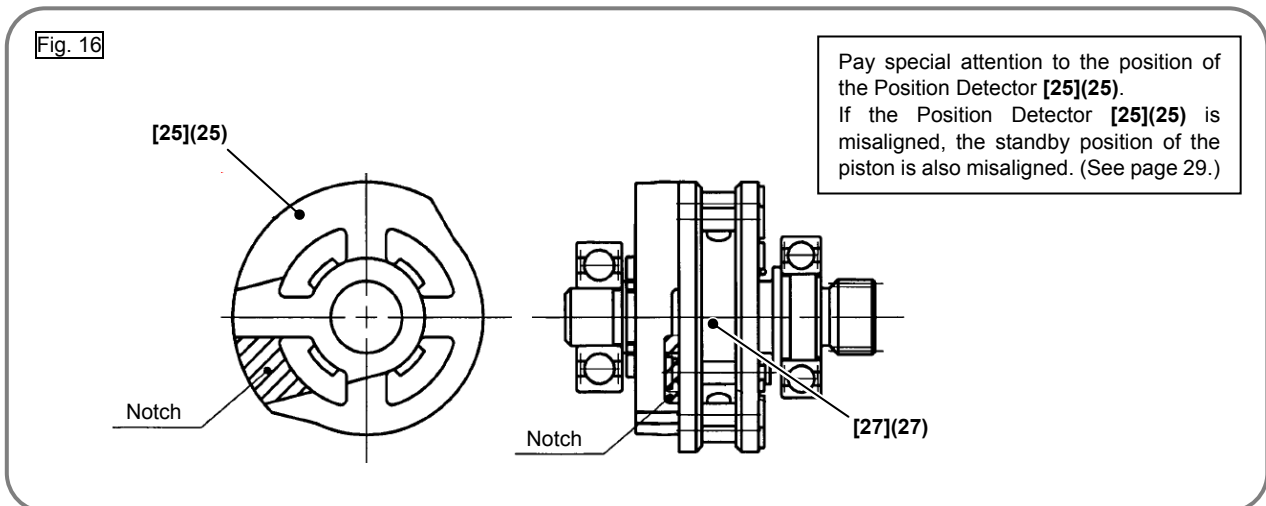

- Remove dust from between the Pin Wheel 27 and Needle Roller D3 30 and apply about 1.5 g of Molub-Alloy 777-1 grease to the Needle Roller D3 30, eight Needle Rollers D4 32, and Needle Roller D4.5 26 evenly.
- Apply about 1.0 g of Isoflex Topas NB52 grease to the X-ring 14 and Slide Ring 13 of the Piston Ass'y 15 evenly.

- Put the Pin Wheel 27 in the Nose 17. Facing the notch of the Pin Wheel 27 to Blade Guide (A) 70, push the Piston Ass'y 15 down to the bottom dead point without meshing with the eight Needle Rollers D4 32 and Needle Roller D4.5 26 as shown in Fig. 17.

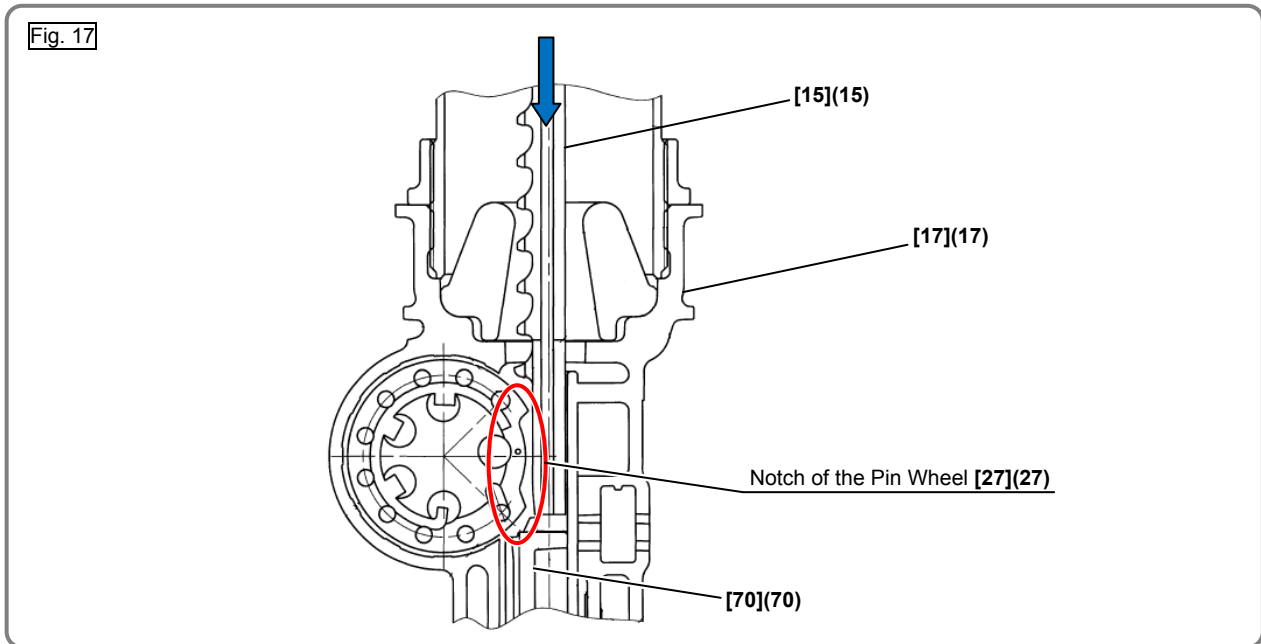

- Mount the Chamber Base 10, Special Nut M58 12, and Nose 17 to the Cylinder 5 in this order. Apply Three-Bond TB1342H adhesive in the form of a line circling around the cylinder two times as shown in Fig. 18. Then mount the Special Nut M58 12.

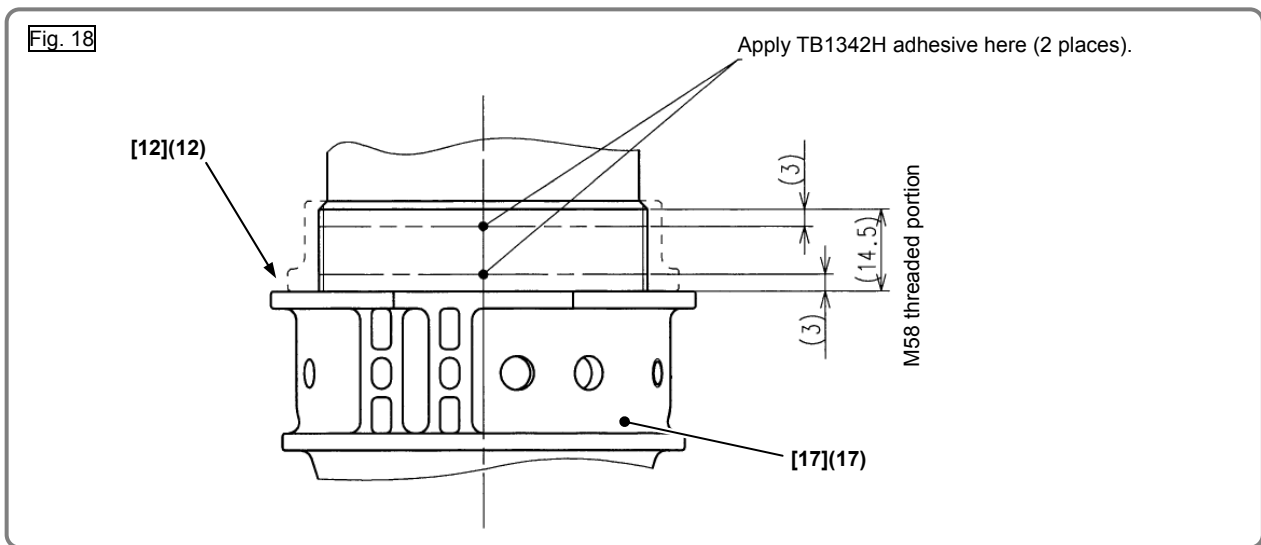

- Mount Sensor (B) 63 using a round bar of 2 to 2.5 mm in diameter as shown in Fig. 19 to protect the root of the wire from being applied force. After mounting Sensor (B) 63, remove the round bar.

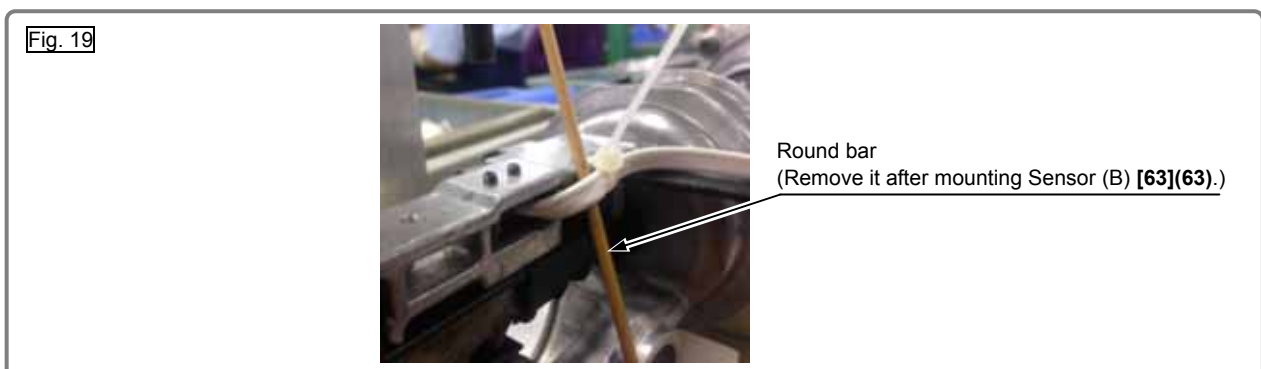

- Apply Molub-Alloy 777-1 grease to the following area on the Nose 17 and then mount Pushing Lever (B) 38.

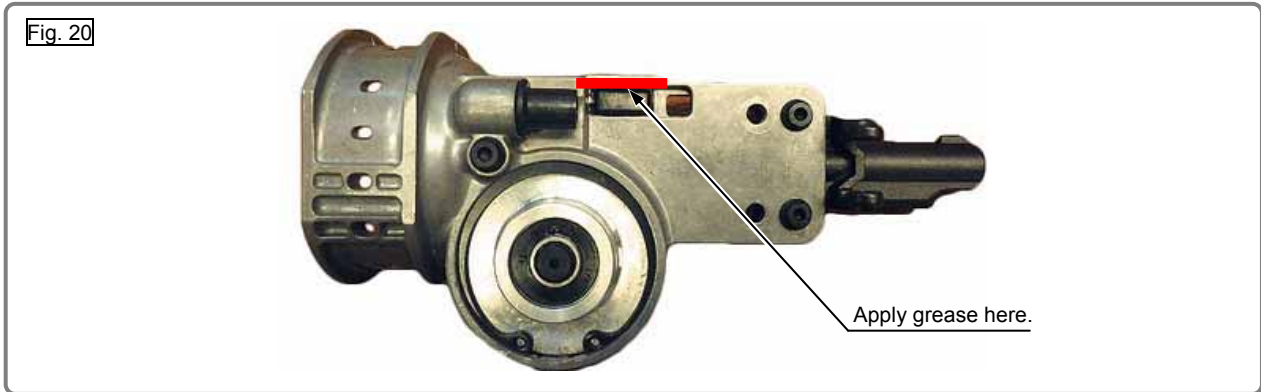

- Be sure to check Sensor (B) 63 according to pages 21 to 22 after reassembling the power assembly.
- Be sure to mount the Hex. Socket Hd. Bolt M5 64 to the Nose 17.
- Insert the Rotor 83 into the Gear Box 82 and check that the Rotor 83 turns smoothly by hand as shown in Fig. 21.

NOTE: If the Rotor 83 cannot turn smoothly, the gear may be deformed or damaged. Replace the Gear Box 82 with new one.



- Be sure to mount Bumper (B) 59 to the Nose 17 as shown in Fig. 22 and then mount the Gear Box 82.

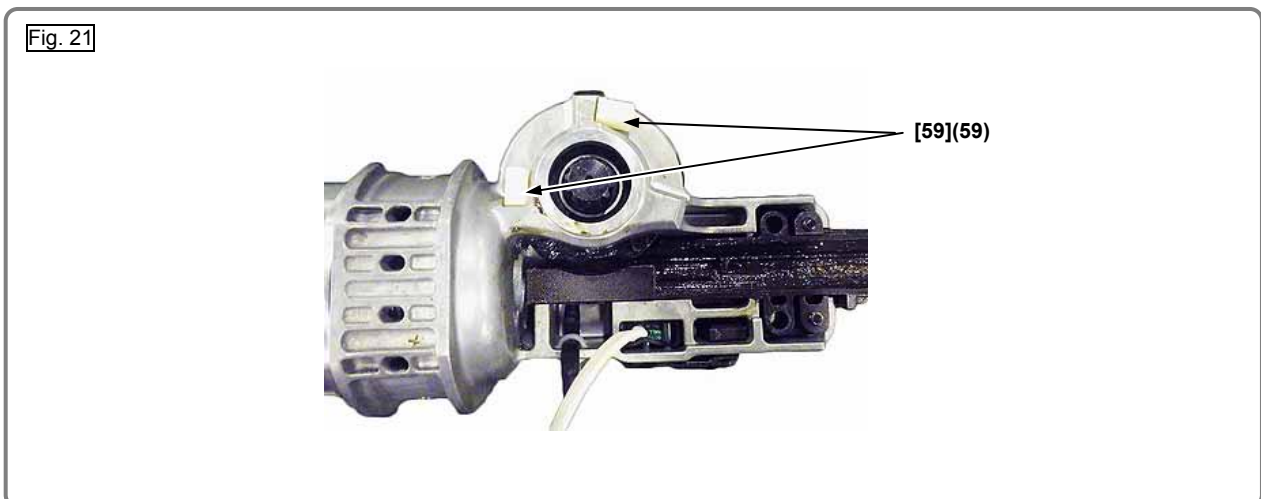

- If it is difficult to mount the Gear Box 82 due to improperly meshed gears, turn the Rotor 83 by hand so that the gears are properly meshed.
- Push the wires in housing (A) of Housing Set 46 with a flat-blade screwdriver being careful not to damage the coating as shown in Fig. 22.

Fig. 22

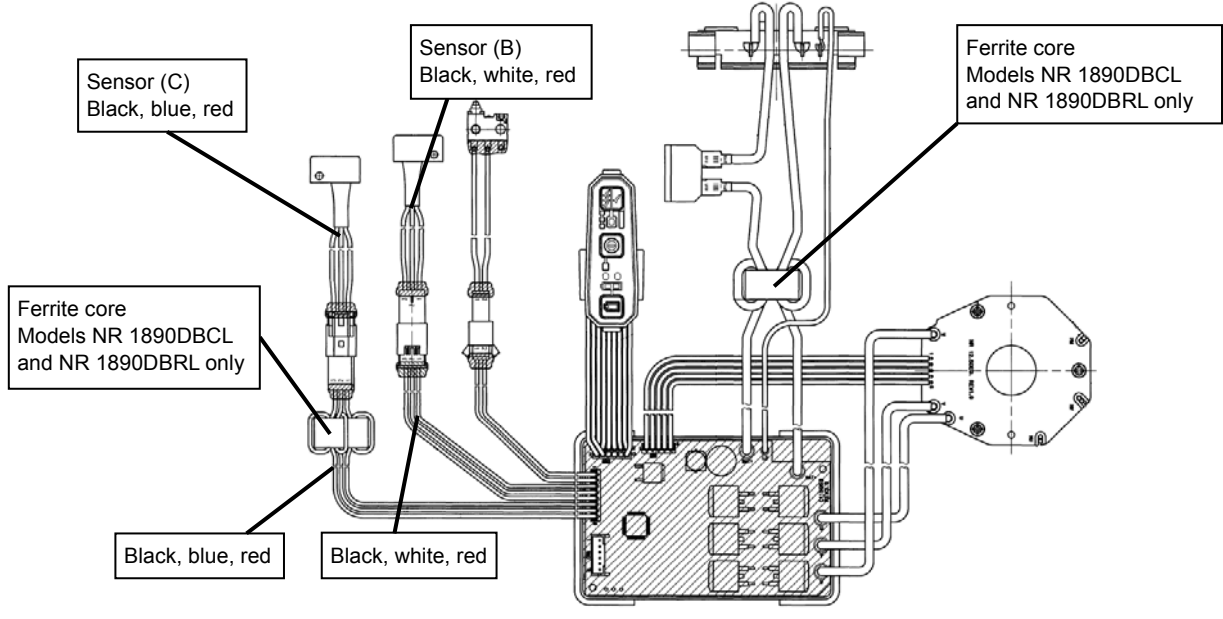
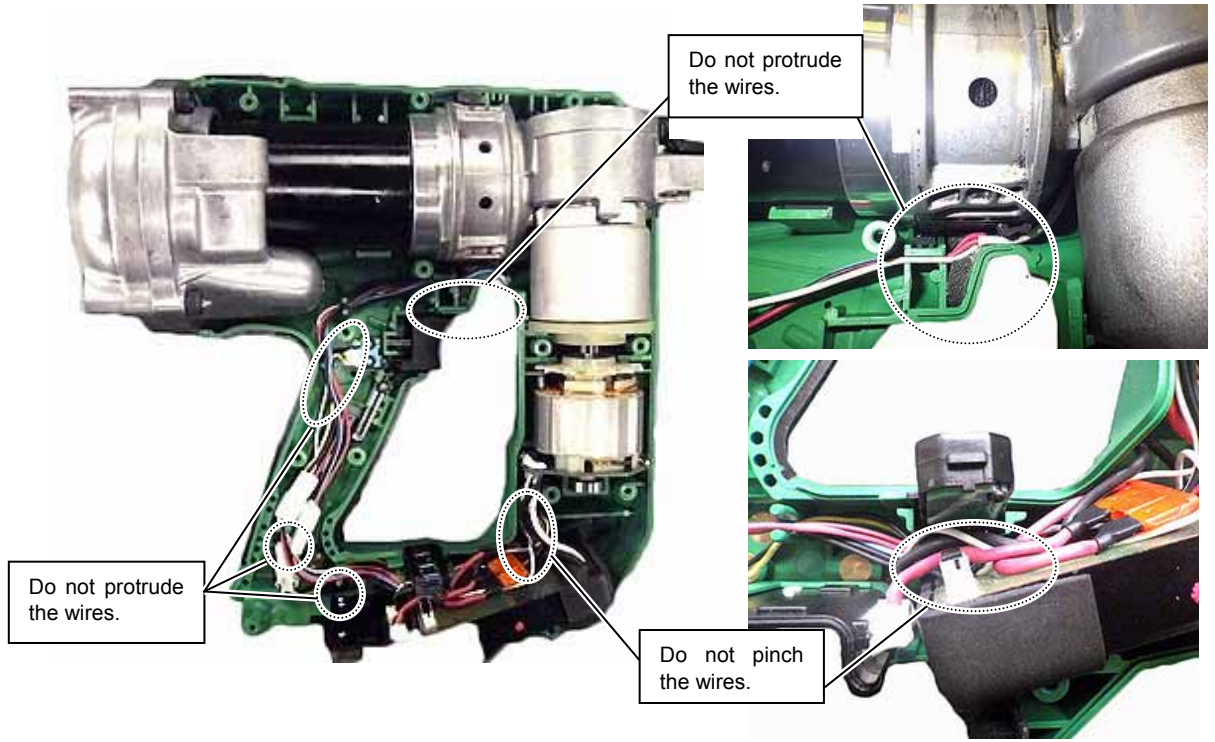

- Check that the wires are not caught and there is no clearance between housings (A) and (B) when putting housing (A) and housing (B) together.

Fig. 23



- After reassembly, check that the terminal of the Wiring 51 is properly mounted without mismatch and it is slightly movable as shown in Fig. 24.

Fig. 24



4. Checking after reassembly of the power assembly

- Check that Pushing Lever (A) 42 moves smoothly without any catch.
- Check that the Adjuster 41 rotates smoothly.
- Connect Sensor (B) 63 and Sensor (C) 60 to the Wiring 51 and then connect the terminal to the battery as shown in Fig. 25 in order to check Sensor (B) 63 for normal response.

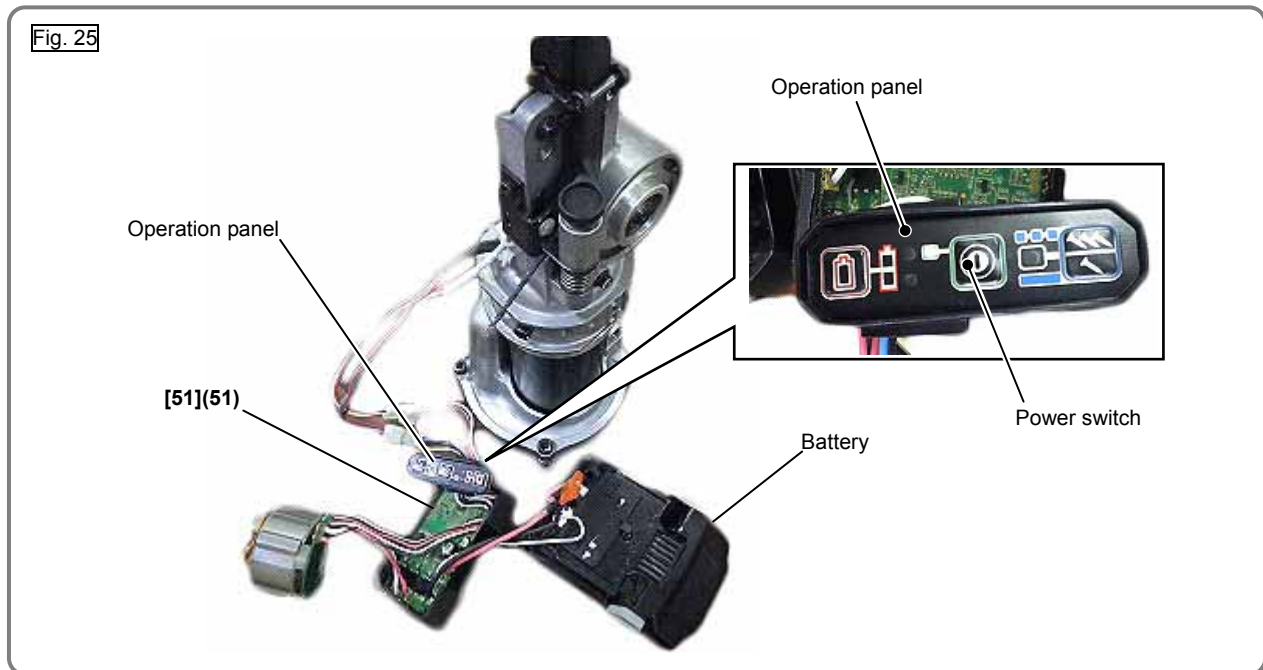

- Insert a pin punch of 5 ± 0.1 mm in diameter between Pushing Lever (B) 38 and the wall of the Nose 17 where Sensor (B) 63 is inserted. Then push in Pushing Lever (A) 42 and keep pressing the power switch on the operation panel for at least 2 seconds. Check that the LED light on the operation panel turns on. Next, insert a pin punch of 2.4 ± 0.1 mm in diameter and push in Pushing Lever (A) 42. Keep pressing the power switch on the operation panel for at least 2 seconds. Check that the LED light on the operation panel remains turned off. (See Fig. 26.)

NOTE: If a pin punch of 5 ± 0.1 mm (0.2 ± 0.0039 ") in diameter and a pin punch of 2.4 ± 0.1 mm (0.095 ± 0.0039 ") in diameter are not available, use the shank of a drill of 5 mm in diameter and a drill of 2.4 mm in diameter.

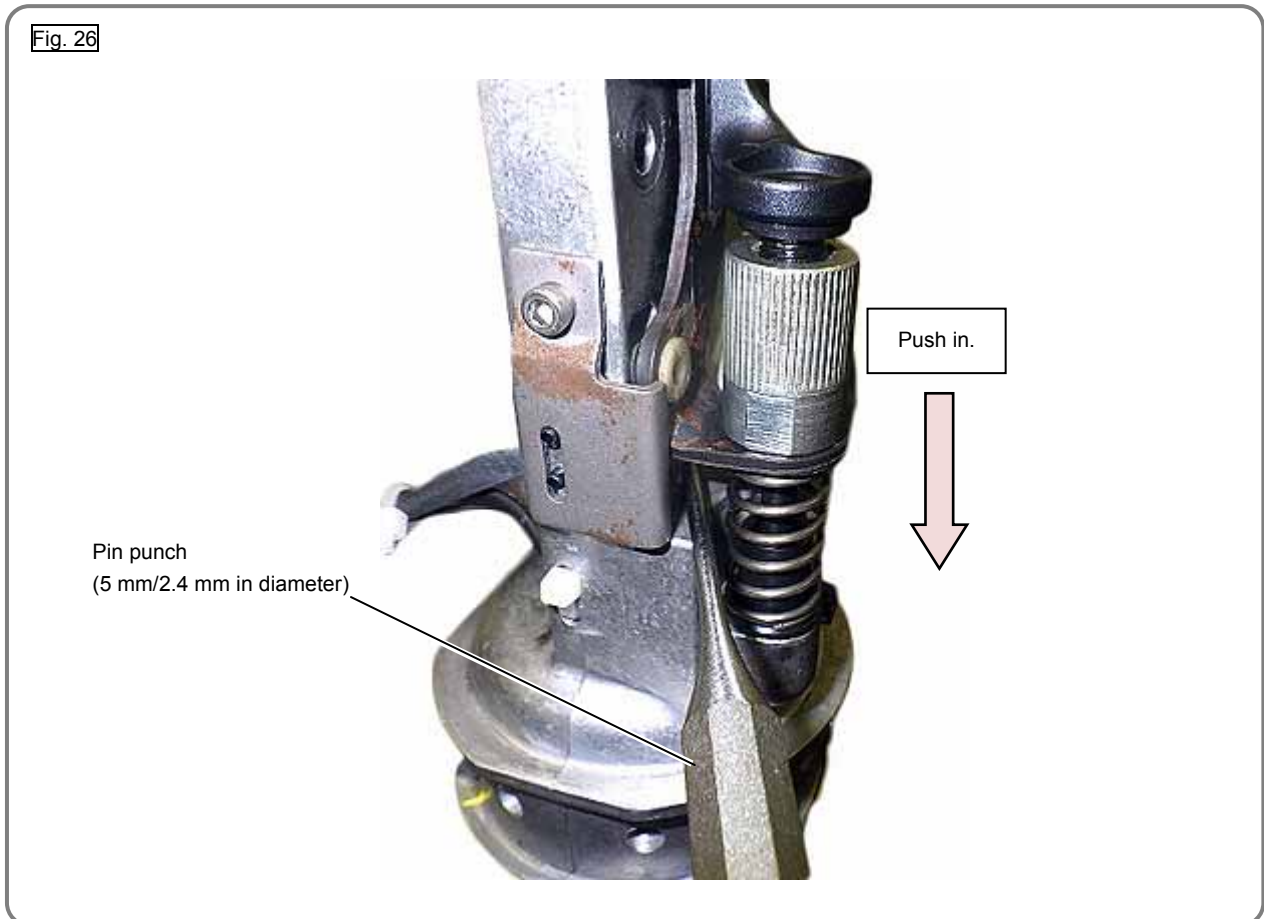

- If the LED light remains turned off when inserting a pin punch of 5 mm in diameter during the operation check of Sensor (B) 63 or if the LED light turns on when inserting a pin punch of 2.4 mm in diameter, Pushing Lever (B) 38, Blade Plate (P) [68](38) or Sensor (B) 63 may be damaged or deformed. Check and replace the damaged or deformed part and then perform the operation check of Sensor (B) 63 again.

Replacement of the piston ass'y

NOTE: When replacing only the Piston Ass'y 15 with new one, also replace the Needle Roller D4.5 26 mounted in the Pin Wheel 27 with new one included in the brand-new Piston Ass'y 15.

1. Disassembly

- Remove Housing (C) 45, magazine ass'y, and Top Cover 2 to take out the power assembly and Wiring 51 referring to pages 8 to 12.

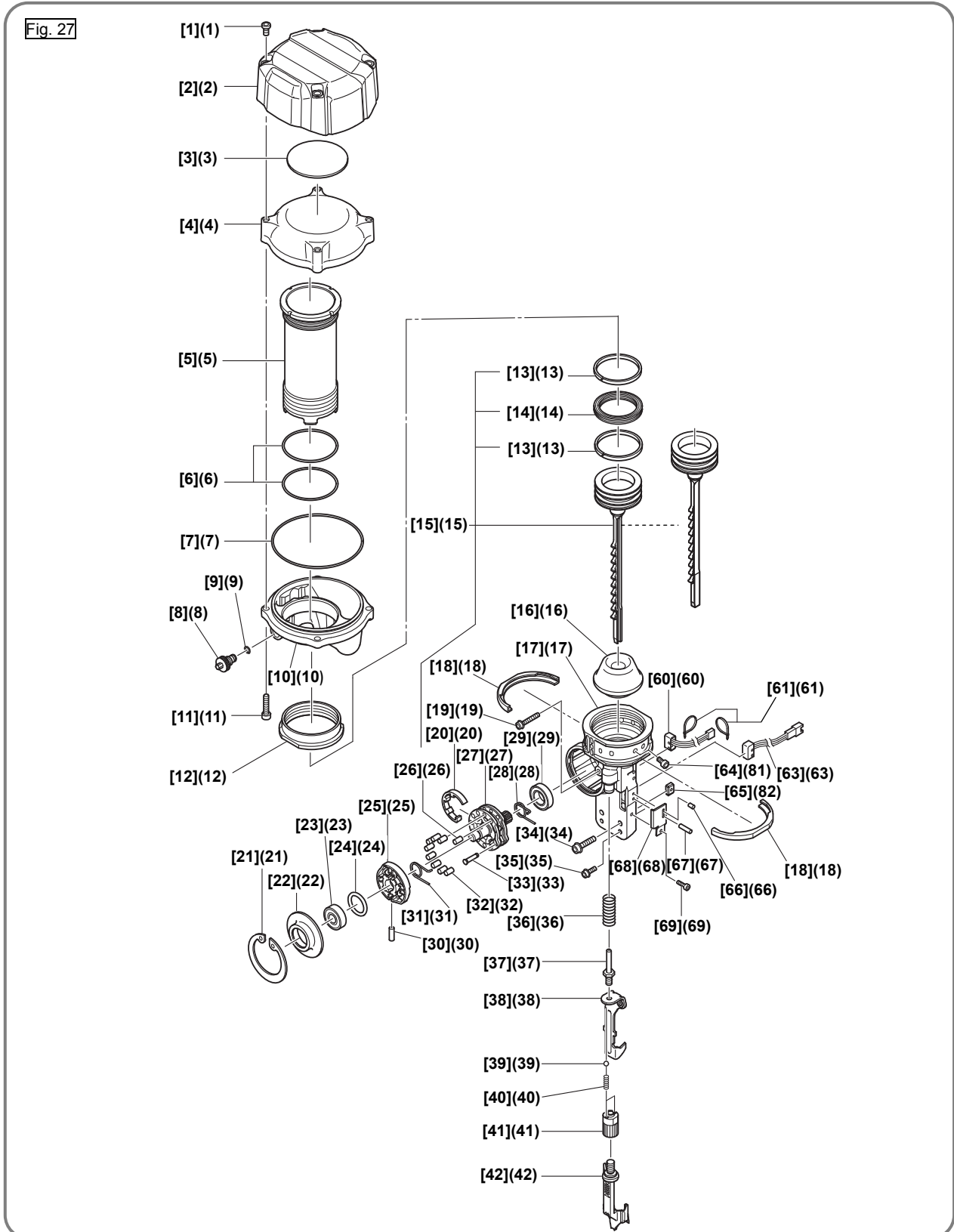

- Check that compressed air is completely released. Then remove the four Nylock Bolts M6 11 from the Chamber Base 10 and Chamber Cover 4 to remove the Chamber Cover 4.

NOTE: If it is difficult to remove the Chamber Base 10, temporarily tighten at least two Nylock Bolts M6 11 so that the threaded portion is shown 3.5 mm to 6.5 mm as shown in Fig. 28. Mount the reduction valve set and feed compressed air to remove the Chamber Base 10.

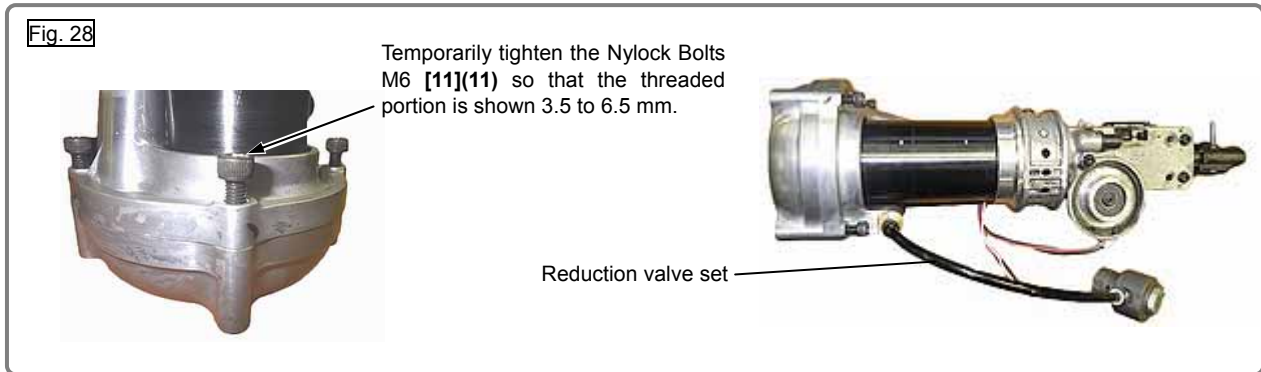

- Push the Piston Ass'y 15 from Blade Guide (A) 70 side toward the Cylinder 5 side to remove it from the Cylinder 5.
- Remove the Retaining Ring D52 21 from the Nose 17 and pull out the Bearing Holder 22 and Pin Wheel 27.
- Remove the Ball Bearing 6000VV 23 from the Pin Wheel 27.
- Remove the Needle Roller D3 30 from the Pin Wheel 27. Then remove the Position Detector 25.
- Remove the Needle Roller D4.5 26 from the Pin Wheel 27. (See Fig. 29.)

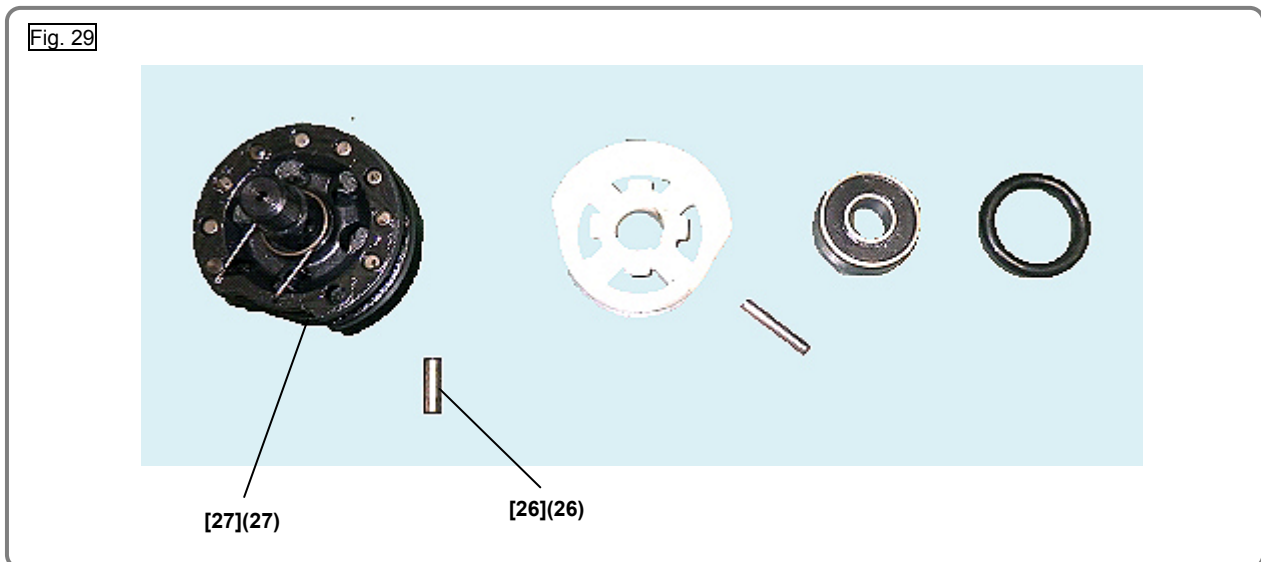

2. Reassembly

Reverse the disassembly procedure to reassemble. Note the following points:

- Use the specified tightening torques.
- Insert the Needle Roller D4.5 26 included in the brand-new Piston Ass'y 15 into the Pin Wheel 27.
- Mount the Pin Wheel 27 to the Position Detector 25 so that the end surface side of Pin (A) 33 is aligned with the notch of the Position Detector 25 as shown in Fig. 30.

Fig. 30

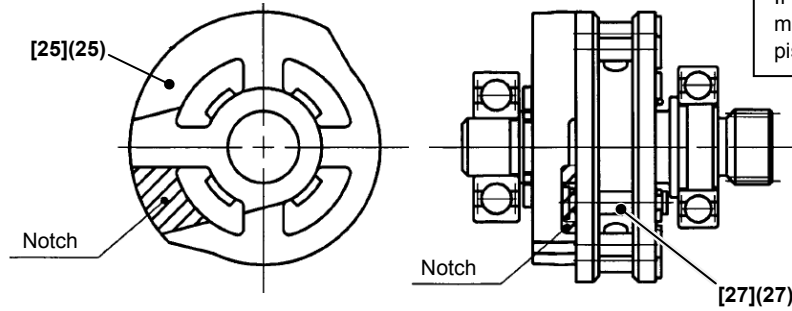

Pay special attention to the position of the Position Detector 25. If the Position Detector 25 is misaligned, the standby position of the piston is also misaligned. (See page 29.)

- Remove dust from between the Pin Wheel 27 and Needle Roller D3 30 and apply about 1.5 g of Molub-Alloy 777-1 grease to the Needle Roller D3 30, eight Needle Rollers D4 32, and Needle Roller D4.5 26 evenly.
- Apply about 0.2 g of Isoflex Topas NB52 grease to the two Slide Rings 13 included in the brand-new Piston Ass'y 15 evenly. Then mount the two Slide Rings 13 to the Piston Ass'y 15.
- Apply about 1.0 g of Isoflex Topas NB52 grease to the X-ring 14 included in the brand-new Piston Ass'y 15 evenly. Then mount the X-ring 14 to the Piston Ass'y 15.
- Put the Pin Wheel 27 in the Nose 17. Facing the notch of the Pin Wheel 27 to Blade Guide (A) 70, push the Piston Ass'y 15 down to the bottom dead point without meshing with the eight Needle Rollers D4 32 and Needle Roller D4.5 26 as shown in Fig. 31. Apply about 1.5 g of Isoflex Topas NB52 grease to the inside of the Cylinder 5 evenly.

NOTE: If the Position Detector 25 is not precisely located, an error (causing the orange LED of the battery indicator to blink) may occur.

Fig. 31

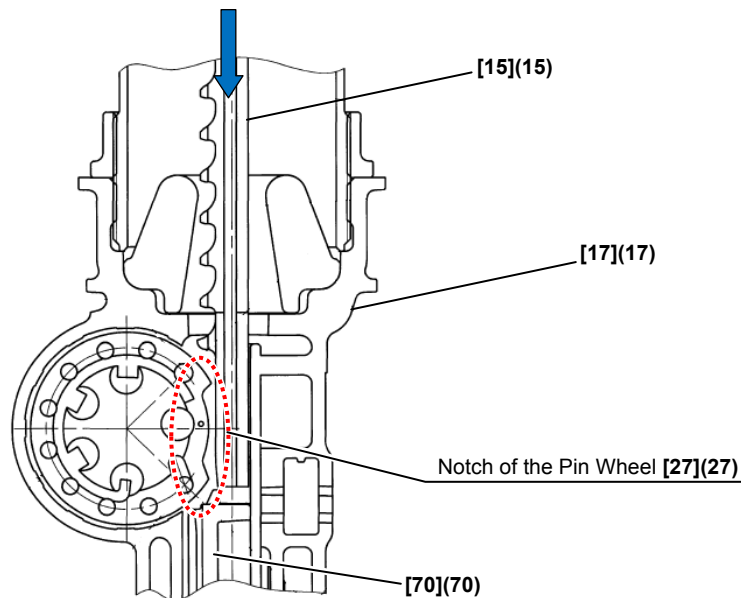

- Slowly tighten the four Nylock Bolts M6 11 to fasten the Chamber Base 10 and Chamber Cover 4. Be careful not to pinch and damage the O-ring (I.D 94.5) 7.
- Perform reassembly of the power assembly according to pages 16 to 20.

Replacement of sensor (B)

- Remove Housing (C) 45, magazine ass'y, and Top Cover 2 to take out the power assembly referring to pages 8 to 12.
- Remove the Nylock Hex. Socket Hd. Bolt M3 69 and Guide Plate Holder 65 from the Nose 17, then remove Guide Plate (P) 68.
- Pull out the Roll Pin D2.5 66 and Roll Pin D2.5 x 16 67 protruding from the Nose 17 with nippers as shown in Fig. 32.

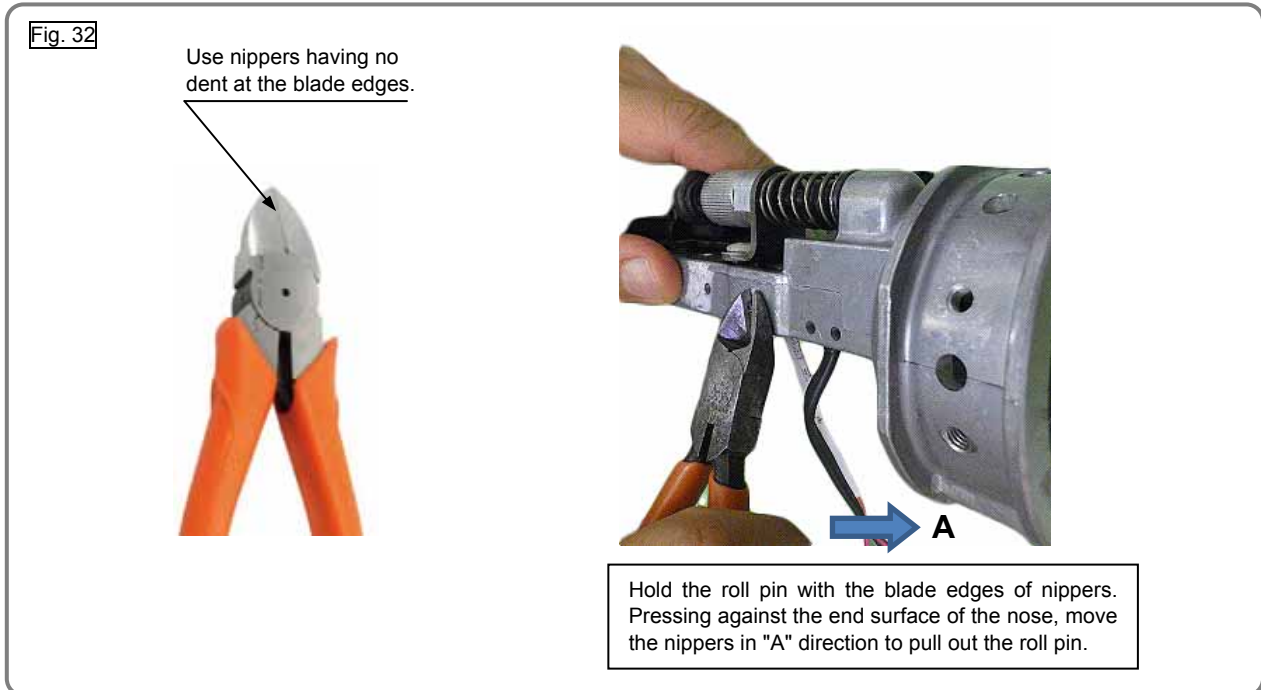

- Remove Sensor (B) 63 from the Nose 17.
- Mount new Sensor (B) 63 to the Nose 17 and then mount the Roll Pin D2.5 66 as shown in Fig. 33.

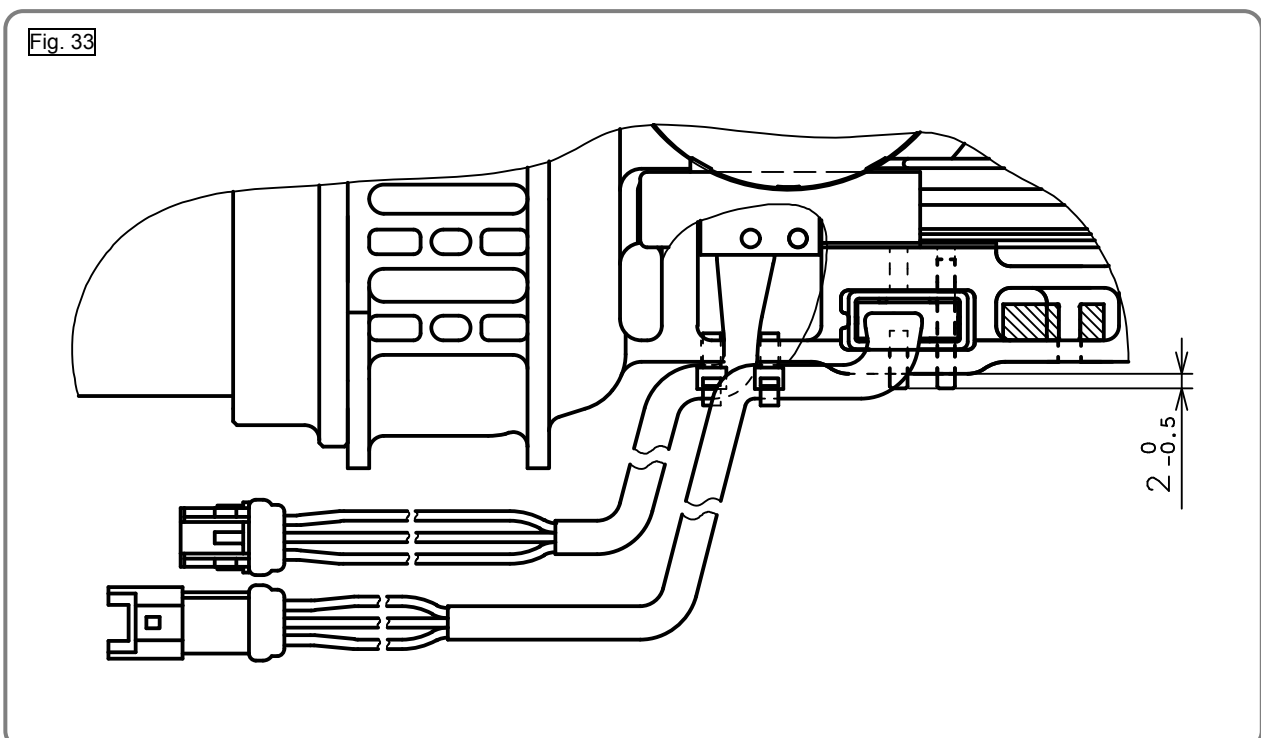

Feeding compressed air

- CAUTION:**
- Be sure to set **MAINTENANCE** mode (see page 7) and move the **Piston Ass'y 15** down to the **bottom dead point** before feeding or discharging compressed air.
 - Be sure to use the specified reduction valve set when feeding compressed air.
 - An oil-free compressor should be used to feed compressed air to the nailer.

1. Moving the piston down to the bottom dead point

- Turn on the nailer and switch to **MAINTENANCE** mode. (See page 7.)
- Repeat the steps below three or four times until the **Piston Ass'y 15** reaches the bottom dead point.
 - (1) Move the **Feeder Knob 92** down to reset the dry-fire lockout mechanism.
 - (2) Press **Pushing Lever (A) 42** against a piece of wood.
 - (3) Pull the **Trigger 54**.
- Check that the driver blade of the **Piston Ass'y 15** protrudes from the blade guide.

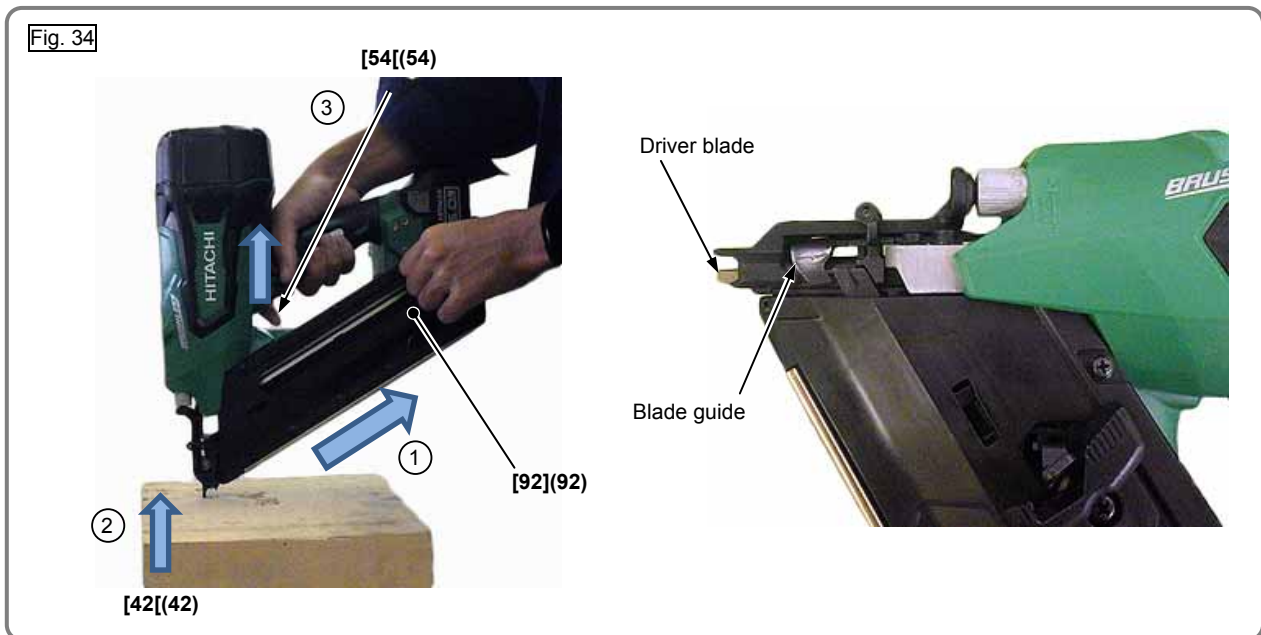

2. Feeding compressed air

- Check that the battery is not mounted in the nailer body.
- Prepare the J-394 reduction valve set (16 GA) specified below.

Model	Model name indicated on label	Repair tool number	Preset feeding pressure
NR1890DC/DBCL NR1890DR/DBRL	NT 1865DM	J-394 (Code No. 371208)	0.5±0.03 MPa (5.1±0.3 kgf/cm ²)

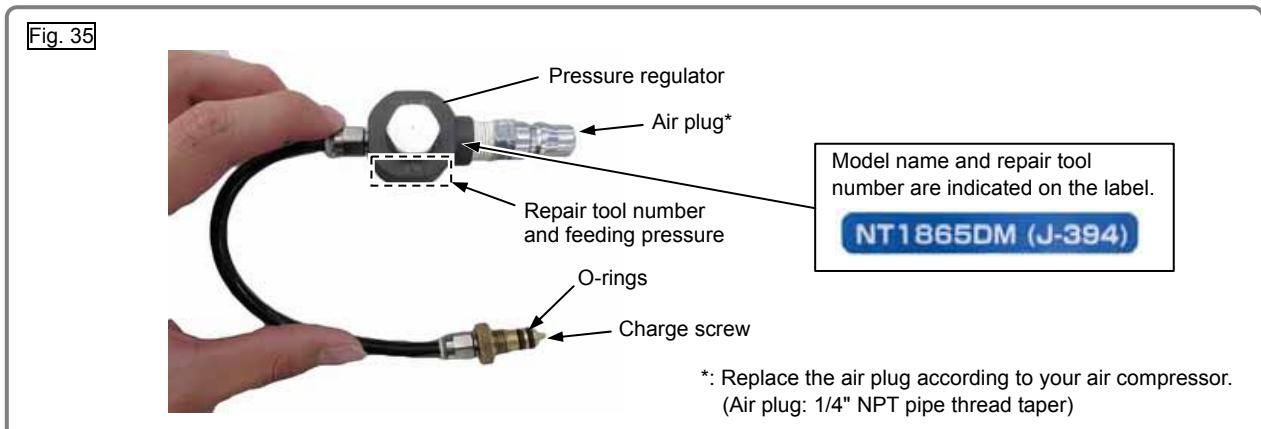

- Push the valve core and check that no compressed air is left.
- Apply lubricant to the O-ring (S-5) (Code No. 872822) of the charge screw. Always replace a defective O-ring with a new one.
- Screw in the charge screw into the pressure feeding port of the Chamber Base **10**.

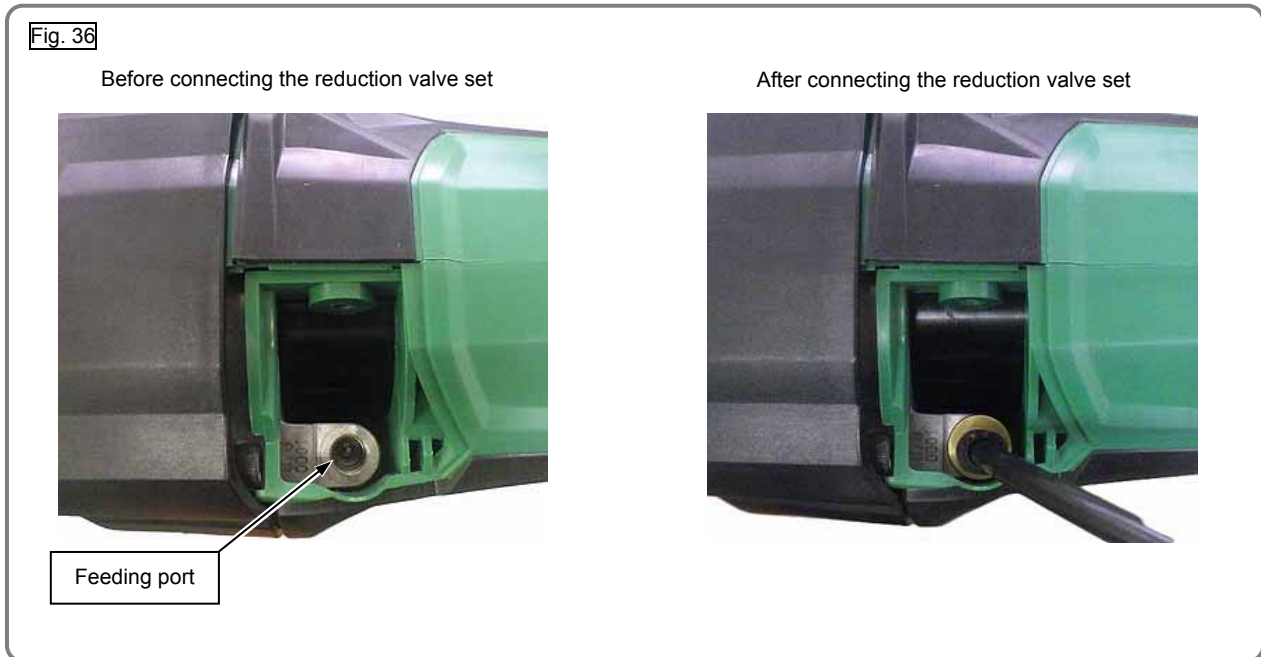

- Prepare an air compressor (0.7 MPa or higher) and set a delivery pressure of 0.7 to 1.2 MPa. (See Fig. 37.)



- Connect the reduction valve set to the air compressor for at least 10 seconds to feed compressed air. (See Fig. 38.)

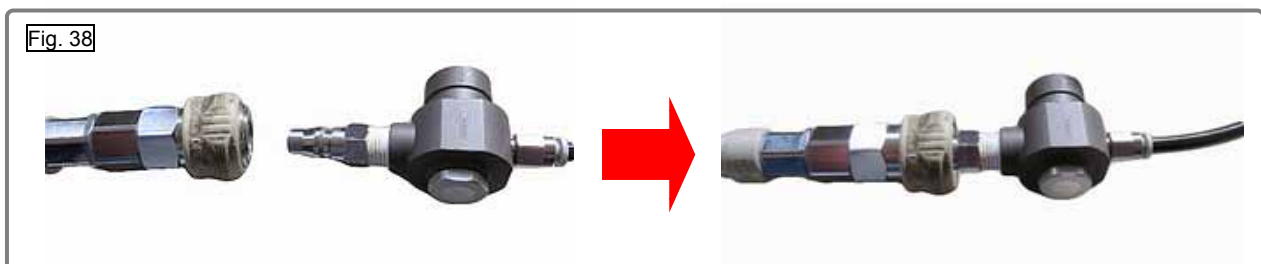

- Reverse the procedure above for disconnection.
- Quickly mount the Charge Cap **8** on the feeding port within 30 seconds after feeding compressed air to prevent air leaks from the valve section.

Checking after reassembly

- Check that no nail is loaded in the magazine.
- Check that Pushing Lever (A) **42** moves smoothly without any catch.
- Check that the Adjuster **41** rotates smoothly.
- Check that the Trigger **54** moves smoothly.
- Check that the Feeder Knob **92** slides smoothly.
- Push Pushing Lever (A) **42** of the empty nailer (without nails) against a wood material and make sure the dry-fire lockout mechanism works normally.
- Move Lever (A) **56** to the LOCK position and make sure the Trigger **54** is completely locked and cannot be pulled back.
- Turn on the nailer and make sure no LED is blinking to indicate an error state.
- Turn on the nailer and make sure the LEDs on the operation panel light.
- Load the longest nails in the nailer and start nailing. Check that no trouble (e.g., abnormal nailing, unusual sound, nail head lift) occurs. Press Pushing Lever (A) **42** without pulling the Trigger **54** in the contact actuation mode and make sure the nailer does not work.
- After checking the actual nailing, check the position-in-readiness according to the following procedure:
Measure the distance between the tip of Blade Guide (A) **70** and the tip of the Piston Ass'y **15** with a caliper and make sure that the distance is 90.2 mm or shorter. If the distance is longer than 90.2 mm, the position detector may be incorrectly mounted. Check whether the position detector is correctly mounted or not. (See page 16.)
- Do not use the nailer for one day after checking the actual nailing, and then check that the nailer works normally without any nail heads lifted on the next day by loading the longest nails in the nailer (air leak check).

Tightening torque

Item No.		Part name	Tightening torque	
NR 1890DC NR 1890DBCL	NR 1890DR NR 1890DBRL		N•m	lbf-ft
[1]	(1)	Hex. Socket Bolt M6	9.8 ± 0.8	7.2 ± 0.6
[5]	(5)	Cylinder	82 ± 3	60.5 ± 0.2
[8]	(8)	Charge Cap	4.5 ± 0.5	3.3 ± 0.4
[11]	(11)	Nylock Bolt M6	12.8 ± 0.8	9.4 ± 0.6
[12]	(12)	Special Nut M58	50 ± 1	36.9 ± 0.7
[19][35]	(19)(35)	Nylock Bolt (W/Flange) M4	3.4 ± 0.7	2.5 ± 0.5
[34][85]	(34)(86)	Nylock Bolt (W/Flange) M5	6.9 ± 0.5	5.1 ± 0.5
[37]	(37)	Special Bolt M6	12.7 ± 0.8	9.4 ± 0.6
[44]	(44)	Tapping Screw (W/Flange) D4 x 20 (Black)	2.0 ± 0.5	1.5 ± 0.2
[58]	(58)	Low Head Hex. Socket Bolt M4 x 8	3.4 ± 0.7	2.5 ± 0.5
[64]	(64)	Hex. Socket Hd. Bolt M5	3.0 ± 0.3	2.2 ± 0.2
[69]	(69)	Nylock Hex. Socket Hd. Bolt M3	2.45 ± 0.5	1.8 ± 0.4
[89]	(89)	Step Bolt M3	1.7 ± 0.17	1.2 ± 0.1
[91]	(91)	Tapping Screw (W/Flange) D4 x 16 (Black)	2.8 ± 0.5	2.0 ± 0.4
[93]	(93)	Tapping Screw (W/Flange) D5 x 20 (Black)	2.9 ± 0.5	2.2 ± 0.4

Connecting diagram

Fig. 39

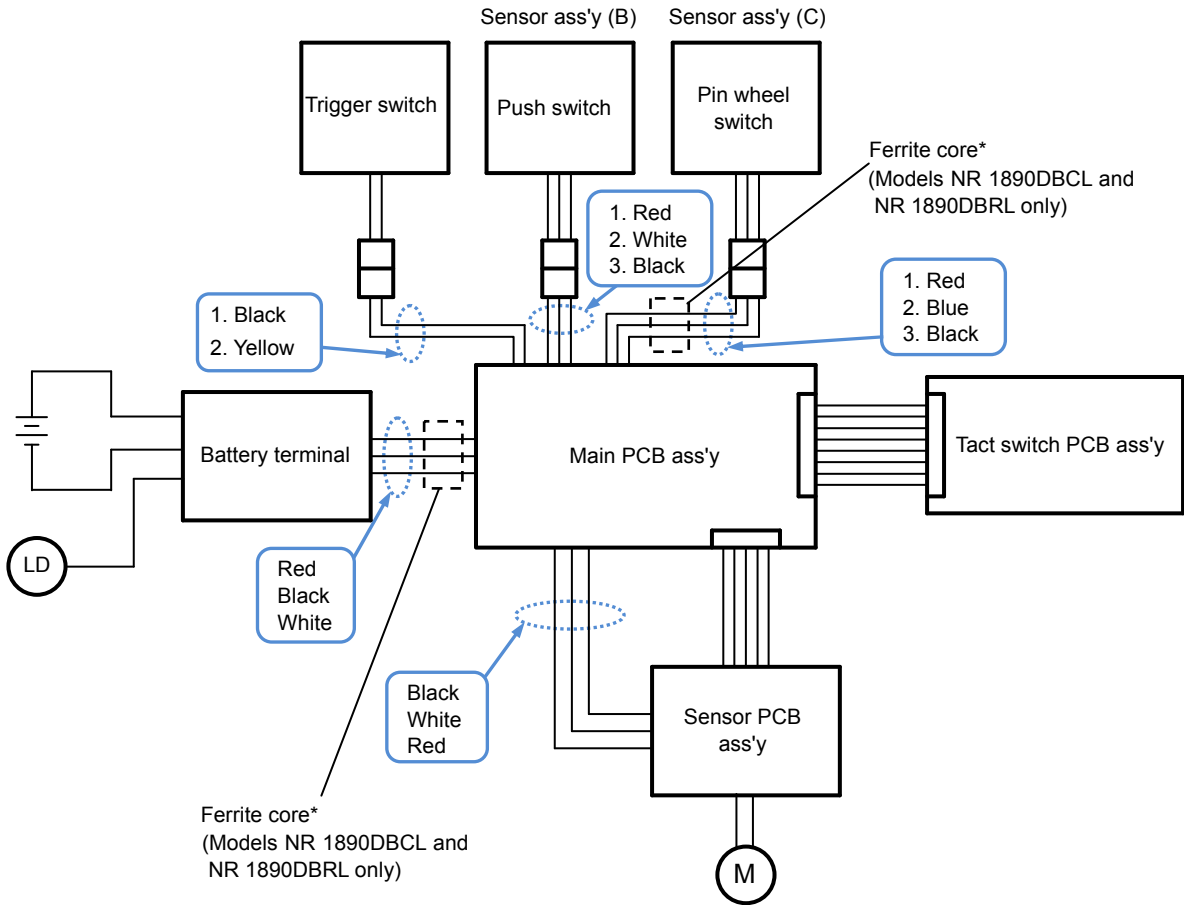

*: Alternative part

STANDARD REPAIR TIME (UNIT) SCHEDULES

MODEL	Variable	10	20	30	40	50	60 min.
<div style="border: 1px solid black; padding: 2px; margin-bottom: 2px;">NR 1890DC</div> <div style="border: 1px solid black; padding: 2px; margin-bottom: 2px;">NR 1890DBCL</div> <div style="border: 1px solid black; padding: 2px; margin-bottom: 2px;">NR 1890DR</div> <div style="border: 1px solid black; padding: 2px;">NR 1890DBRL</div>		<div style="border: 1px solid black; padding: 2px; margin-bottom: 2px;">Work Flow</div>			<div style="border: 1px solid black; padding: 2px; margin-bottom: 2px;">Pin Wheel Position Detector</div>	<div style="border: 1px solid black; padding: 2px; margin-bottom: 2px;">Adjuster Pushing Lever (A)</div> <div style="border: 1px solid black; padding: 2px;">Pushing Lever (B) Magnet</div>	
	<div style="border: 1px solid black; padding: 2px;">General Assembly</div>	<div style="border: 1px solid black; padding: 2px; margin-bottom: 2px;">Top Cover Housing (C)</div> <div style="border: 1px solid black; padding: 2px; margin-bottom: 2px;">Hook Pushing Lever</div> <div style="border: 1px solid black; padding: 2px;">Spring</div>	<div style="border: 1px solid black; padding: 2px; margin-bottom: 2px;">Blade Guide (B)</div> <div style="border: 1px solid black; padding: 2px; margin-bottom: 2px;">Magazine Cover (A)</div> <div style="border: 1px solid black; padding: 2px; margin-bottom: 2px;">Magazine Cover (B)</div> <div style="border: 1px solid black; padding: 2px; margin-bottom: 2px;">Nail Rail Magazine</div> <div style="border: 1px solid black; padding: 2px; margin-bottom: 2px;">Guard Magazine Plate</div> <div style="border: 1px solid black; padding: 2px; margin-bottom: 2px;">Pushing Stopper (A)</div> <div style="border: 1px solid black; padding: 2px; margin-bottom: 2px;">Pushing Stopper (B)</div> <div style="border: 1px solid black; padding: 2px; margin-bottom: 2px;">Pushing Stopper Spring</div> <div style="border: 1px solid black; padding: 2px; margin-bottom: 2px;">Feeder Knob</div> <div style="border: 1px solid black; padding: 2px; margin-bottom: 2px;">Nail Feeder (B)</div> <div style="border: 1px solid black; padding: 2px; margin-bottom: 2px;">Ribbon Spring</div> <div style="border: 1px solid black; padding: 2px;">Nail Feeder</div>	<div style="border: 1px solid black; padding: 2px; margin-bottom: 2px;">Chamber Cover</div> <div style="border: 1px solid black; padding: 2px; margin-bottom: 2px;">Chamber Base</div> <div style="border: 1px solid black; padding: 2px; margin-bottom: 2px;">Special Nut M58</div> <div style="border: 1px solid black; padding: 2px; margin-bottom: 2px;">O-ring x 2</div> <div style="border: 1px solid black; padding: 2px; margin-bottom: 2px;">Cylinder</div> <div style="border: 1px solid black; padding: 2px; margin-bottom: 2px;">Piston Blade</div> <div style="border: 1px solid black; padding: 2px; margin-bottom: 2px;">Slide Ring</div> <div style="border: 1px solid black; padding: 2px; margin-bottom: 2px;">X-Ring</div> <div style="border: 1px solid black; padding: 2px; margin-bottom: 2px;">Piston Bumper</div> <div style="border: 1px solid black; padding: 2px; margin-bottom: 2px;">Housing Trigger Rotor</div> <div style="border: 1px solid black; padding: 2px; margin-bottom: 2px;">Wiring Sensor (C)</div> <div style="border: 1px solid black; padding: 2px;">Gear Box</div>	<div style="border: 1px solid black; padding: 2px; margin-bottom: 2px;">Blade Guide (A)</div> <div style="border: 1px solid black; padding: 2px; margin-bottom: 2px;">Sensor (B)</div> <div style="border: 1px solid black; padding: 2px;">Nose</div>		

PNEUMATIC TOOL PARTS LIST

CORDLESS STRIP NAILER Model NR 1890DC

2017·7·12
(E1)

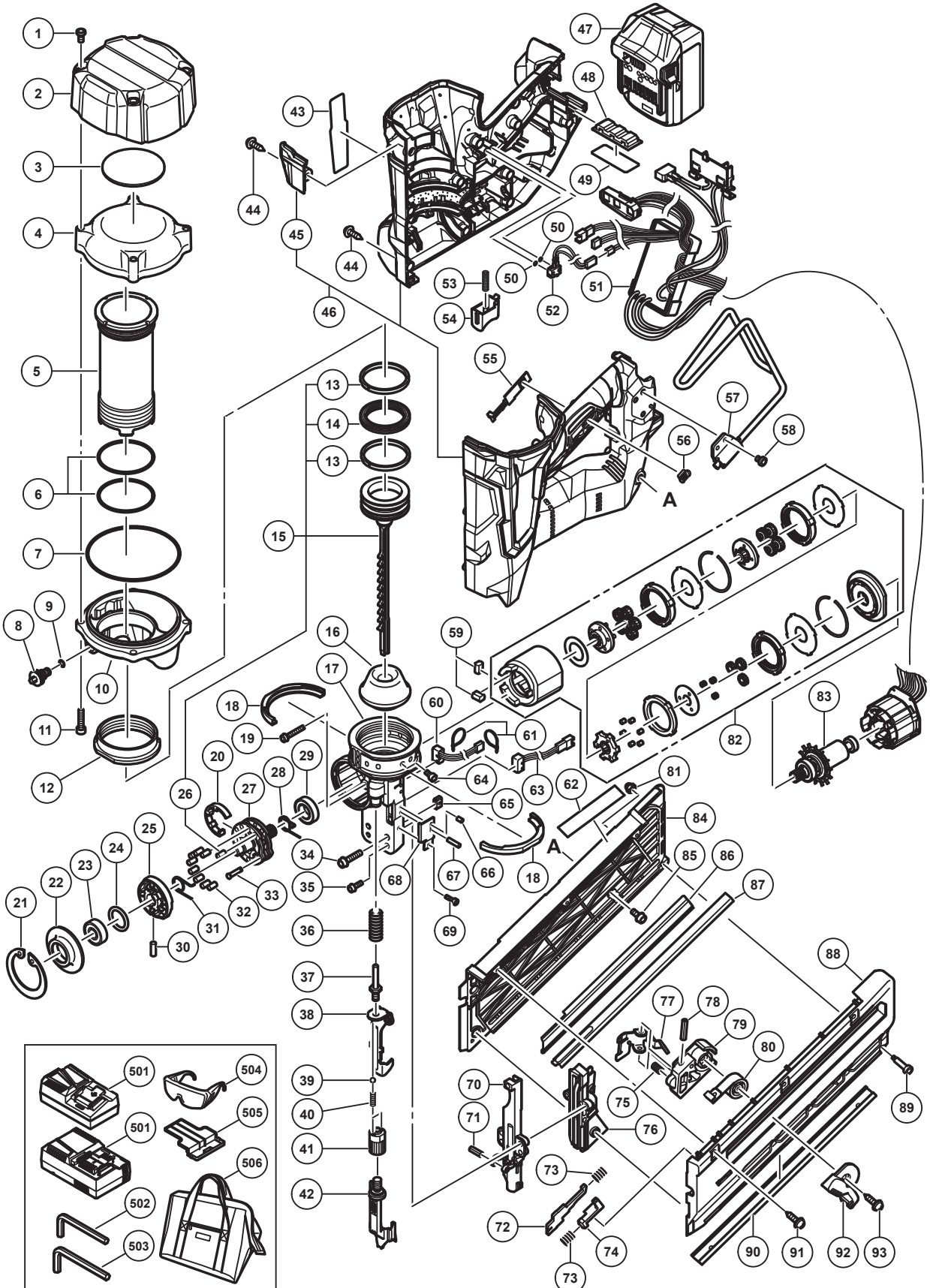

PARTS

NR 1890DC

ITEM NO.	CODE NO.	DESCRIPTION	NO. USED	REMARKS
1	372298	HEX. SOCKET BOLT M6	4	
2	372296	TOP COVER	1	
3	371012	RUBBER CUSHION (C)	1	
4	372337	CHAMBER COVER	1	
5	372335	CYLINDER	1	
6	372336	O-RING (I.D 55.5)	2	
7	372334	O-RING (I.D 94.5)	1	
8	371039	CHARGE CAP	1	
9	872822	O-RING (S-5)	1	
10	372388	CHAMBER BASE	1	
11	372338	NYLOCK BOLT M6	4	
12	372339	SPECIAL NUT M58	1	
13	372320	SLIDE RING	2	
14	372319	X-RING	1	
15	372318	PISTON ASS'Y	1	INCLUD.13,14,26
16	372317	PISTON BUMPER	1	
17	372387	NOSE	1	
18	372343	RUBBER CUSHION (A)	2	
19	372310	NYLOCK BOLT (W/FLANGE) M4 X 25	1	
20	372330	FELT (P)	1	
21	372332	RETAINING RING D52	1	
22	372331	BEARING HOLDER	1	
23	6000VV	BALL BEARING 6000VVCMP2L	1	
24	372329	O-RING (I.D 20.22)	1	
25	372327	POSITION DETECTOR	1	
26	372326	NEEDLE ROLLER D4.5	1	
27	372321	PIN WHEEL	1	
28	372323	WHEEL SPRING (B)	1	
29	6902VV	BALL BEARING 6902VV	1	
30	372328	NEEDLE ROLLER D3	1	
31	372322	WHEEL SPRING (A)	1	
32	372325	NEEDLE ROLLER D4	8	
33	372324	PIN (A)	1	
34	372355	NYLOCK BOLT (W/FLANGE) M5 X 22	2	
35	372311	NYLOCK BOLT (W/FLANGE) M4 X 14	2	
36	372307	PUSHING LEVER SPRING (B)	1	
37	372316	SPECIAL BOLT M6	1	
38	372305	PUSHING LEVER (B)	1	
39	959148	STEEL BALL D3.175 (10 PCS.)	2	
40	372315	ADJUSTER SPRING	2	
41	372314	ADJUSTER	1	
42	372308	PUSHING LEVER (A)	1	
43		NAME PLATE	1	
44	301653	TAPPING SCREW (W/FLANGE) D4 X 20 (BLACK)	14	
45	372297	HOUSING (C)	1	
46	372295	HOUSING SET	1	INCLUD.45
* 47	338890	BATTERY BSL 1860 (USA,CAN)	1	INCLUD.505
* 47	339782	BATTERY BSL 1830C (USA,CAN)	1	INCLUD.505
48	332668	RUBBER CUSHION	1	
49	372803	PLATE (A)	1	

PNEUMATIC TOOL PARTS LIST

CORDLESS STRIP NAILER
Model NR 1890DR

2017·7·12
(E1)

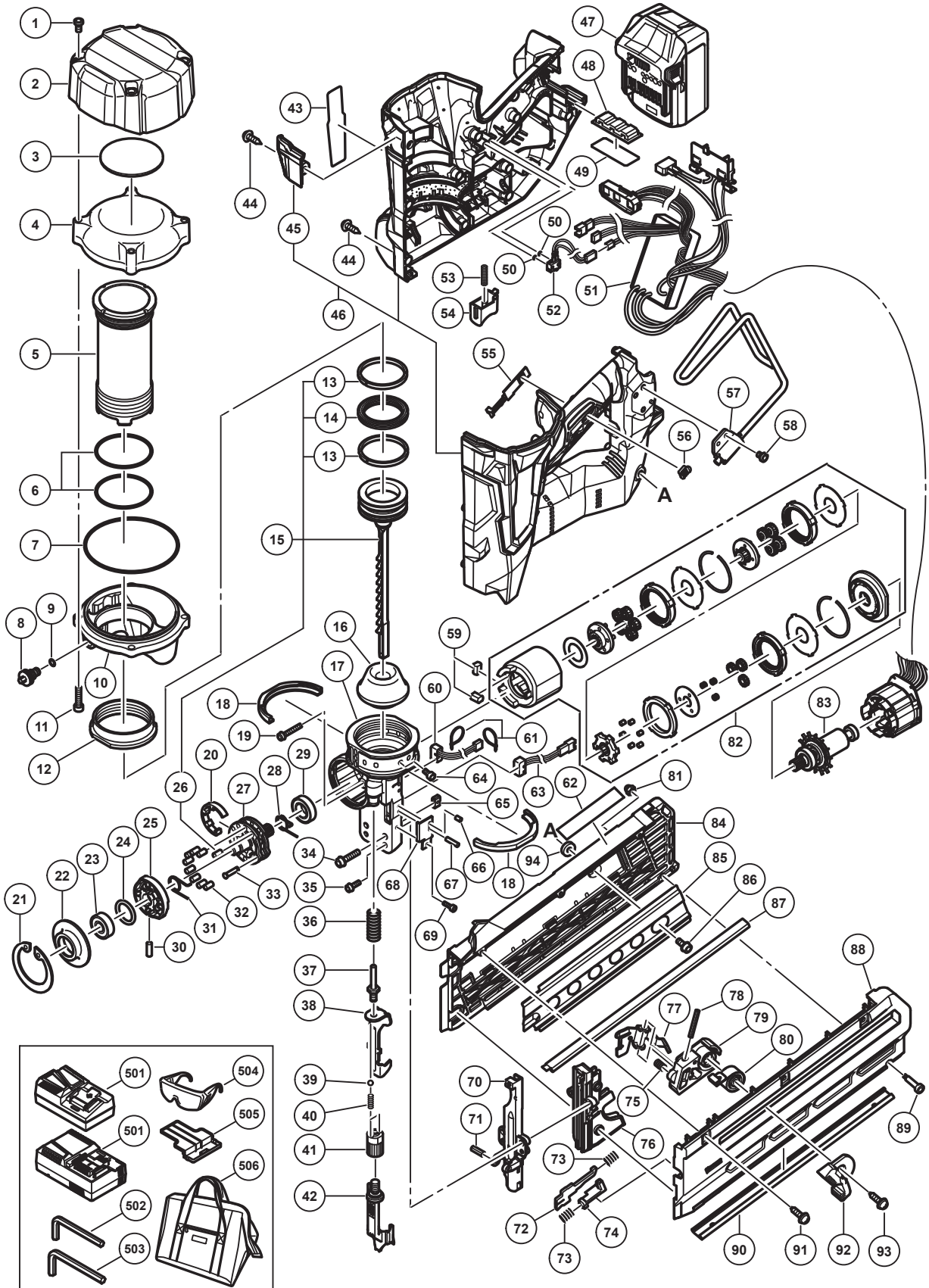

PARTS

NR 1890DR

ITEM NO.	CODE NO.	DESCRIPTION	NO. USED	REMARKS
1	372298	HEX. SOCKET BOLT M6	4	
2	372296	TOP COVER	1	
3	371012	RUBBER CUSHION (C)	1	
4	372337	CHAMBER COVER	1	
5	372335	CYLINDER	1	
6	372336	O-RING (I.D 55.5)	2	
7	372334	O-RING (I.D 94.5)	1	
8	371039	CHARGE CAP	1	
9	872822	O-RING (S-5)	1	
10	372388	CHAMBER BASE	1	
11	372338	NYLOCK BOLT M6	4	
12	372339	SPECIAL NUT M58	1	
13	372320	SLIDE RING	2	
14	372319	X-RING	1	
15	371810	PISTON ASS'Y	1	INCLUD.13,14,26
16	372317	PISTON BUMPER	1	
17	372387	NOSE	1	
18	372343	RUBBER CUSHION (A)	2	
19	372310	NYLOCK BOLT (W/FLANGE) M4 X 25	1	
20	372330	FELT (P)	1	
21	372332	RETAINING RING D52	1	
22	372331	BEARING HOLDER	1	
23	6000VV	BALL BEARING 6000VVCMP2L	1	
24	372329	O-RING (I.D 20.22)	1	
25	372327	POSITION DETECTOR	1	
26	372326	NEEDLE ROLLER D4.5	1	
27	372321	PIN WHEEL	1	
28	372323	WHEEL SPRING (B)	1	
29	6902VV	BALL BEARING 6902VV	1	
30	372328	NEEDLE ROLLER D3	1	
31	372322	WHEEL SPRING (A)	1	
32	372325	NEEDLE ROLLER D4	8	
33	372324	PIN (A)	1	
34	372355	NYLOCK BOLT (W/FLANGE) M5 X 22	2	
35	372311	NYLOCK BOLT (W/FLANGE) M4 X 14	2	
36	372307	PUSHING LEVER SPRING (B)	1	
37	372316	SPECIAL BOLT M6	1	
38	372305	PUSHING LEVER (B)	1	
39	959148	STEEL BALL D3.175 (10 PCS.)	2	
40	372315	ADJUSTER SPRING	2	
41	372314	ADJUSTER	1	
42	372308	PUSHING LEVER (A)	1	
43		NAME PLATE	1	
44	301653	TAPPING SCREW (W/FLANGE) D4 X 20 (BLACK)	14	
45	372297	HOUSING (C)	1	
46	372295	HOUSING SET	1	INCLUD.45
* 47	338890	BATTERY BSL 1860 (USA,CAN)	1	INCLUD.505
* 47	339782	BATTERY BSL 1830C (USA,CAN)	1	INCLUD.505
48	332668	RUBBER CUSHION	1	
49	372803	PLATE (A)	1	

PARTS

NR 1890DR

ITEM NO.	CODE NO.	DESCRIPTION	NO. USED	REMARKS
50	371020	O-RING (I.D 2.5)	2	
51	372291	WIRING	1	
52	371019	SWITCH CABLE (A)	1	
53	332000	SPRING (T)	1	
54	371021	TRIGGER	1	
55	331790	LEVER (C)	1	
56	326276	LEVER (A)	1	
57	372356	HOOK	1	
58	331109	LOW HEAD HEX. SOCKET BOLT M4 X 8	3	
59	372342	BUMPER (B)	2	
60	372302	SENSOR (C)	1	
61	6696839	WIRE BAND	2	
62	371107	CAUTION LABEL	1	
63	372301	SENSOR (B)	1	INLCUD.38
64	372340	HEX. SOCKET HD. BOLT M5	1	
65	372313	GUIDE PLATE HOLDER	1	
66	372304	ROLL PIN D2.5	1	
67	878965	ROLL PIN D2.5 X 16	1	
68	372312	BLADE PLATE (P)	1	
69	331184	NYLOCK HEX. SOCKET HD. BOLT M3	1	
70	371804	BLADE GUIDE (A)	1	
71	949685	ROLL PIN D3 X 20 (10 PCS.)	1	
72	371809	PUSHING LEVER STOPPER (A)	1	
73	372350	SPRING	2	
74	372351	PUSHING LEVER STOPPER (B)	1	
75	883687	SPRING	1	
76	371805	BLADE GUIDE (B)	1	
77	885621	NAIL FEEDER	1	
78	949506	ROLL PIN D4 X 28 (10 PCS.)	1	
79	885324	NAIL FEEDER (B)	1	
80	885325	RIBBON SPRING	1	
81	372353	CAP NUT M3	1	
82	372341	GEAR BOX	1	
83	361071	ROTOR	1	
84	371807	MAGAZINE COVER (B)	1	
85	371808	MAGAZINE PLATE	1	
86	372809	NYLOCK BOLT (W/FLANGE) M5 X 18	1	
87	372811	NAIL RAIL (C)	1	
88	371806	MAGAZINE COVER (A)	1	
89	372352	STEP BOLT M3	1	
90	372348	MAGAZINE GUARD	1	
91	307811	TAPPING SCREW (W/FLANGE) D4 X 16 (BLACK)	3	
92	886246	FEEDER KNOB	1	
93	302089	TAPPING SCREW (W/FLANGE) D5 X 20 (BLACK)	1	
94	372810	WASHER D14.5	1	

